

CRANFIELD UNIVERSITY

Susan Michaelis

IMPLEMENTATION OF THE REQUIREMENTS FOR THE
PROVISION OF CLEAN AIR IN CREW AND PASSENGER
COMPARTMENTS USING THE AIRCRAFT BLEED AIR SYSTEM

Transport Systems
Safety and Accident Investigation Centre

MSc
Academic Year: 2011 - 2016

Supervisors: Graham Braithwaite, Tony Jackson
June 2016

CRANFIELD UNIVERSITY

Transport Systems
Safety and Accident Investigation Centre

MSc

Academic Year 2011 - 2016

Susan Michaelis

IMPLEMENTATION OF THE REQUIREMENTS FOR THE
PROVISION OF CLEAN AIR IN CREW AND PASSENGER
COMPARTMENTS USING THE AIRCRAFT BLEED AIR SYSTEM

Supervisors: Graham Braithwaite, Tony Jackson
June 2016

This thesis is submitted in partial fulfilment of the requirements for
the degree of Master of Science

© Cranfield University 2016. All rights reserved. No part of this
publication may be reproduced without the written permission of the
copyright owner.

ABSTRACT

There are certification and airworthiness requirements related to the provision of clean crew and passenger compartment breathing air utilising the aircraft bleed air system. There have been continuing reports and studies over the years regarding oil fumes in aircraft including impaired crew performance. Oil fumes are viewed in varying ways ranging from low occasional seal bearing failures, to low-level leakage in normal or failure conditions.

The aim of this research is to assess whether there is any gap between the certification requirements for the provision of clean air in crew and passenger compartments and the theoretical and practical implementation of the requirements using the bleed air system.

A comprehensive literature search reviewed applicable certification standards and the documented and theoretical understanding of oil leakage. Interviews were undertaken to address the research questions. These involved the key aviation regulators and the process by which they certify and ensure compliance with the clean air requirements. Aerospace engineers and sealing professionals were interviewed about their understanding of how oil may leak past compressor oil bearing seals, and into the air supply under various flight conditions.

The overall objective of this thesis is intended to contribute to flight safety by analysing the theoretical and practical implementation of the use of the compressor bleed air system to supply the required air quality under the regulatory requirements. The final outcome of the evaluation showed that there is a gap between the clean air certification requirements and the theoretical and practical implementation of the requirements using the bleed air system. Low-level oil leakage in normal flight operations is a function of the design of the pressurised oil and bleed air systems. The use of the bleed air system to supply the regulatory required air quality standards is not being met or being enforced as required.

Keywords - cabin air quality; oil fumes; cabin air contamination; synthetic jet lubricants; jet oils; oil bearing seals; labyrinth seals; carbon seals; bleed air; TCP.

ACKNOWLEDGEMENTS

I gratefully acknowledge the following people and organisations.

- Professor Graham Braithwaite, Cranfield University, for agreeing to let me undertake this important research.
- Dr Tony Jackson and Ron Midgley, Cranfield University, for providing continuing support and encouragement to undertake study into what is an engineering field, when my background is as a pilot.
- Many engineers and experts globally that have helped me to understand this highly specialised field.
- The GCAQE and the UK Independent Pilots Association.
- Captain Tristan Loraine BCAi.
- The doctors who helped me back to health after being diagnosed with cancer in the middle of this MSc.

TABLE OF CONTENTS

ABSTRACT.....	i
ACKNOWLEDGEMENTS.....	iii
LIST OF FIGURES	viii
LIST OF TABLES	ix
LIST OF ABBREVIATIONS	x
1 INTRODUCTION	1
1.1 Research Background.....	1
1.2 Aims and Objectives	3
1.2.1 Aim	3
1.2.2 Objectives	4
1.3 Thesis Structure	4
2 LITERATURE REVIEW	7
2.1 Background Cabin Air Contamination	7
2.1.1 Reports.....	7
2.1.2 Frequency and Under-reporting.....	9
2.1.3 Exposure Data.....	10
2.1.4 Safety	11
2.1.5 Actions	11
2.1.6 Issues.....	12
2.2 Certification Standards	16
2.2.1 CS and FAR Standards and Guidance Material	16
2.2.1.1 Equipment and Systems Design - Airframe.....	16
2.2.1.2 Safety Analysis - Engine and APU.....	18
2.2.1.3 Bleed Air.....	19
2.2.1.4 Airworthiness - Ventilation and Heating.....	20
2.2.1.5 Unsafe Condition.....	20
2.2.2 Other Standards and Regulations	20
2.3 Oil System	21

2.3.1 Oil bearing Chamber Sealing	22
2.3.2 Secondary Air	22
2.3.3 Oil Supply to Main Bearings	23
2.3.4 Bearing Compartment Sealing	24
2.3.5 Bleed Air for Pressurisation and Ventilation	25
2.3.6 Oil Bearing Seals	27
2.3.6.1 Labyrinth Seals	28
2.3.6.2 Mechanical Contact Seals	30
2.3.7 Common Aspects of Oil Bearing Seal Operation	32
2.3.8 Awareness of Oil Bearing Seal Leakage	34
2.3.9 Choice of Bearing Seals.....	36
2.3.10 Fluid Leakage Controls.....	38
2.3.11 Oil Leakage Under Normal or Failure Conditions	38
2.4 Summary	39
3 METHODOLOGY	42
3.1 Purpose of Research	42
3.2 Data Collection Method	42
3.3 Ethical Considerations	44
3.4 Development of Interview Questions.....	44
3.5 Data Analysis	45
3.6 Validity	45
3.7 Limitations.....	46
4 DEVELOPMENT AND RESULTS OF INTERVIEWS.....	48
4.1 Engineers.....	48
4.1.1 General.....	48
4.1.2 Demographics	48
4.1.3 Interview Objectives.....	48
4.1.4 Limitations	48
4.1.5 Analysis of Results	49
4.2 Aviation Regulators	61
4.2.1 General.....	61
4.2.2 Interview Objectives.....	61
4.2.3 Limitations	61

4.2.4 Analysis of results	62
5 DISCUSSION	68
5.1 Introduction	68
5.2 Overview of Research Methods	68
5.3 Research Objectives Discussion.....	68
5.3.1 Standards and Guidance Material.....	68
5.3.2 Theoretical Understanding.....	69
5.3.3 Feasibility of Implementation of Standards	71
5.3.4 Reluctance to Change	76
6 CONCLUSIONS AND RECOMMENDATIONS	78
6.1 Conclusions.....	78
6.1.1 Regulations & Standards	78
6.1.2 Design	79
6.1.3 Compliance	79
6.1.4 Preventative Control Measures	79
6.1.5 Retrospectively	80
6.1.6 Expertise and Communication	80
6.2 Recommendations and Future research.....	80
6.3 Research Objectives and Accomplishments.....	81
REFERENCES	85
APPENDICES	101
Appendix A Selected Oil Fume Activities 1999-2016	103
Appendix B EASA and FAA Certification Requirements and Guidance Material - Airframe and Engine/APU.....	107
Appendix C Engine Oil System	111
Appendix D Seal Technology Comparison.....	115

LIST OF FIGURES

FIGURE 1: AMC - PROBABILITY VS SEVERITY	17
FIGURE 2: CS 25.1309 AMC: PROBABILITY VS SEVERITY.....	18
FIGURE 3: BEARING COMPARTMENT PRESSURISATION – CFM	24
FIGURE 4: OIL BEARING SUMP	25
FIGURE 5: LABYRINTH SEALS SCHEMATICS	28
FIGURE 6: BASICS OF LABYRINTH SEALING.....	29
FIGURE 7: MECHANICAL CARBON FACE SEALS.....	31
FIGURE 8: PARTIAL PRESSURES CAUSING VAPOUR LEAKAGE AGAINST PRESSURE GRADIENT.....	33
Figure C1: Engine Oil System - Trent 500	111
Figure C2: Jet Engine Oil Systems	112
Figure C3: Simplified Oil System Schematic Sections	112

LIST OF TABLES

Table 1: EASA Airframe and Engine/APU CS and AMC.....	73
Table A:1 Selected Oil Fume Activities 1999-2016.....	103
Table B:1 EASA And FAA Certification Requirements and AMC - Airframe and Engine.....	107
Table D:1 Seal Technology Comparison	115

LIST OF ABBREVIATIONS

A-NPA	Advance Notice of Proposed Amendment
AAIB	Air Accidents Investigation Branch
AC	Advisory Circular
ACER	Airliner Cabin Environmental Research
ACGIH	American Conference of Governmental Industrial Hygienists
AMC	Acceptable Means of Compliance
APU	Auxiliary Power Unit
APU OH	Auxiliary Power Unit Operating Hour
ARP	Aerospace Recommended Practice
ASHRAE	American Society of Heating, Refrigerating and Air-Conditioning Engineers
ATSB	Australian Transport Safety Bureau
BALPA	British Air Line Pilots Association
BASI	Bureau of Air Safety Investigation (now part of ATSB)
BFU	German Accident Investigation Board
CAA	Civil Aviation Authority (UK)
CASA	Civil Aviation Safety Authority of Australia
CAQ	Cabin Air Quality
CO	Carbon Monoxide
CO ₂	Carbon Dioxide
COT	Committee on Toxicity of Chemicals in Food, Consumer Products and the Environment
CS	Certification Specifications
CS-APU	Certification Specifications - Auxiliary Power Units
CS-E	Certification Specifications - Engines
EASA	European Aviation Safety Agency
ECA	European Cockpit Association
ECS	Environmental Control System
EFH	Engine Flight Hours
EPAAQ	Expert Panel on Aircraft Air Quality
FAA	Federal Aviation Administration
FAR	Federal Aviation Regulations
FH	Average Probability Per Flight Hour

GCAQE	Global Cabin Air Quality Executive
HEPA	High Efficiency Particulate Air
HP	High Pressure
IATA	International Air Transport Association
ICAO	International Civil Aviation Organization
ICSO	International Civil Service Commission
IFALPA	International Federation of Air Line Pilots' Associations
IGHRC	Interdepartmental Group on Health Risks from Chemicals
JAR	Joint Aviation Requirements
LP	Low Pressure
NASA	National Aeronautics and Space Administration
NRC	National Research Council
OEM	Original Equipment Manufacturers
OHRCA	Occupational Health Research Consortium in Aviation
O ₃	Ozone
PCA	Parliament of the Commonwealth of Australia
PPM	Parts per Million
REACH	Registration, Evaluation, Authorisation and Restriction of Chemicals
SAE	Society of Automotive Engineers
SAE ARP	Society of Automotive Engineers Aerospace Recommended Practice
SFC	Specific Fuel Consumption
SHK	Swedish Accident Investigation Board
SS	Steady State
TCP	Tri-Cresyl Phosphate
TOCP	Tri-Ortho-Cresyl Phosphate
TSO	Technical Standard Order
USAF	United States Air Force

1 INTRODUCTION

1.1 Research Background

The issue of aircraft air supplies contaminated by engine oils has continued for many years and remains ongoing. There is a wide range of military and civilian aviation reports dating from the early 1950s through to the present, expressing concerns about bleed air contamination. Exposure to a range of hazardous substances and pyrolysis by-products, from engine oils and hydraulic fluids contaminating the aircraft air supply, is increasingly recognised as potentially adversely impacting flight safety. Despite no real time monitoring to detect compressor bleed air contamination, a growing number of studies have confirmed the presence of low levels of oil substances in the air supply, swab tests and HEPA filters in normal operations. While the significance of exposure continues to be questioned, an increasing number of global initiatives continue to be undertaken.

Despite general acceptance that aircraft cabin air can become contaminated by oil substances generated within the engine or Auxiliary Power Unit (APU) on a somewhat regular basis, the frequency of such exposures is widely debated. Most within the aviation industry and government, suggest that oil leakage and subsequent fumes contaminating the crew and passenger breathing air supply in the aircraft cabin is infrequent, occurring only on the rare occasion of oil seal failure and selected operational factors such as worn seals or oil reservoir overfill. Suggested frequency of bleed air contamination events ranges widely from as low as 2.7 events per million aircraft departures, to more recent estimations of 2.1 events per 10,000 departures, to 1% of all flights. However, under-reporting is also stated to be significant.

There is now some limited increasing recognition that oil fumes may occur as a design factor or deficiency with use of the bleed air system, in addition to seal failure and operational factors. Outside the oil seals and engineering specialist areas, low level oil leakage during normal flight is increasingly being reported. The leakage is suggested to occur during various phases of engine operation,

with low-level leakage across oil seals occurring on a continuous to varying or intermittent basis. This lower level leakage related to system design and operation of utilising oil seals reliant upon compressed air (which is also used to supply the aircraft bleed air) is often viewed as normal, safe and acceptable. Such oil leakage is suggested to be associated with minor discomfort only, however increased levels due to wear or failure are possibly affecting occupant health and flight safety.

Within the specialist oil sealing community there is wide recognition that oil sealing systems, which are reliant upon compressor pressurised air to seal the bearing chambers, are responsive to a variety of engine conditions. This allows lower levels of oil to be transported out through the seals into the compressor air. Oil supplied under high pressure to the main shaft bearings performs various functions, however leakage outside the chamber may result in various serious adverse effects, such as performance loss, fires or oil pollution. Conventional oil seals are generally recognised to enable low-level leakage under various phases of flight, with questions raised over which seals are optimal for bearing compartment sealing under the wide variety of operating conditions.

There are clear regulatory standards and guidelines available that outline the requirements for clean air to be supplied to the crew and passenger compartments.

There are two varying positions held within the aviation industry regarding the leakage of oil outside the bearing chamber. In the wider aviation industry, outside of the seal and engineering specialist areas, the more common position held is that leakage is a function of seal failure or operational deficiencies. The second view comes from an increasing understanding that low-level leakage occurs at various phases of normal flight. The specialist sector tends to support the latter position, however their views are not commonly available.

Therefore given this discrepancy between the regulatory standards and two varying positions, a natural question can be raised. Does oil leakage out of the bearing chamber occur only in the occasional failure or maintenance deficiency

scenario, or as a normal part of engine operation when using pressurised oil seals and compressor bleed air to supply cabin air? The aim of this research is to therefore assess whether there is any gap between the certification requirements for the provision of clean air in the crew and passenger compartments and the theoretical and practical implementation of the requirements using the bleed air system.

The following report contains two sets of interviews to understand the practical implementation of the clean air regulatory requirements. Twelve highly experienced aviation and seals engineers were asked to provide their understanding of how oil may leak internally within the engines with a focus on leakage past compressor oil bearing seals.

The European Aviation Safety Agency (EASA) and the Federal Aviation Administration (FAA) were asked about their practical implementation of the certification and airworthiness requirements ensuring compliance for the purity of the bleed air supply to the aircraft cabin.

Both interview types will be analysed along with the theoretical previously reported understanding of the use of the bleed air system and oil leakage in relation to the regulatory requirements. Therefore, it should be possible to determine if there is any gap between the practical implementation of providing clean air to aircraft cabins when using the bleed air system and the required regulatory standards.

The report will also contain conclusions and recommendations for possible further work required that might be applicable to aircraft utilising the engine bleed air system for breathing and pressurisation purposes.

1.2 Aims and Objectives

1.2.1 Aim

The aim of this research is to assess whether there is any gap between the aircraft certification requirements for the provision of clean air in crew and

passenger compartments of transport aircraft using the bleed air system and the theoretical and practical implementation of the requirements.

1.2.2 Objectives

To evaluate the aircraft certification requirements for the provision of clean air in crew and passenger compartments, and the processes in ensuring their compliance.

To assess the theoretical documented understanding of the potential conditions in an aircraft bleed air system that may lead to contamination of air supplied into the crew and passenger compartments.

To assess the feasibility of the implementation of the aircraft certification requirements for the provision of clean air in crew and passenger compartments in a real world situation, specifically in the context of the potential contamination caused by various conditions in the aircraft bleed air system.

To provide conclusions, recommendations and future research for the aviation industry and authorities with regard to the provision of clean air in crew and passenger compartments using the aircraft bleed air system.

1.3 Thesis Structure

This thesis consists of six chapters. The initial chapters cover the objectives of the thesis; the certification standards for the provision of clean air in crew and passenger compartments, and the current understanding of cabin air contamination in relation to the aircraft bleed air system. The final chapters contain the analysis, discussion and conclusions regarding the objectives set out above.

Chapter 1 - Introduction - Contains information on the background to the research subject matter and a brief summary of the project. The aims and objectives are set out along with the chapter layout.

Chapter 2 - Literature review - Reviews the existing literature regarding applicable standards and the present documented and theoretical

understanding of turbine engine oil leakage past oil-bearing seals into the cabin. This will set up the research questions and provide the context for undertaking the research.

Chapter 3 - Research methodology - Describes the research methodologies used to undertake this research.

Chapter 4 - Results - The results and analysis of two interview-based research questions: interviews with key aviation regulators, about the process by which they certify and ensure compliance with the clean air requirements; and interviews with engineers and sealing professionals, about their understanding of how oil may leak past oil-bearing seals into the air supply under various flight operational conditions.

Chapter 5 - Discussion - A critical discussion with a detailed analysis of the project in terms of results obtained and literature related to the objectives.

Chapter 6 - Conclusions and Recommendations - This chapter contains a summary of the work undertaken, a list of conclusions and recommendations for possible further work required that might be applicable to aircraft utilising the engine bleed air system for breathing and pressurisation purposes.

2 LITERATURE REVIEW

2.1 Background Cabin Air Contamination

Concerns about exposure to jet engine oils leaking from the engine into the cabin air supply are extensive and ongoing over many decades.

2.1.1 Reports

The first reports of concerns of exposure to jet oils leaking from aircraft engines into cabin air supplies dates back to the early 1950s. This coincided with the introduction of synthetic jet engine oils that replaced mineral oils and the introduction of higher performing, higher temperature and pressure turbine engines (Johnson et al.,1952; Davidson et al.,1955). However, the toxicity was deemed speculative with the possible toxic effect still unknown (Johnson et al., 1952, Gutkowski et al.,1953). Temperatures of the oils and bearings increased requiring better oil compatibility with the engine seals to minimise seal leakage (Crampton et al.,1952). Both the military and aircraft industry became aware of repeated reports of adverse effects related to the presence of smoke and fumes, associated with the thermal decomposition of engine oils. These were attributed to oil leaking into the compressor of turbine engines (Gutkowski et al., 1953; Reddall, 1955; Kitzes, 1956). Studies undertaken by the US military in the 1950s into the inhalation toxicity of heated oils, found that the thermal degradation of the oil base stock became very toxic when exposed to high temperatures (Treon et al.,1955).

Manufacturer studies reported occurrences were completely erratic with no predictable pattern, as the contamination occurred at all phases of flight (Waddock, 1954), increasing during changes in engine power conditions and engine start-up (Gutkowski, 1953). Studies on personnel exposed to the heated oils, reported adverse effects (Loomis and Krop, 1955; Ensor, 1960). Zero oil leakage, although difficult to obtain under all operating conditions was recognised as necessary due to the use of compressor bleed air to pressurise and refrigerate the cabin (Palsulich and Riedel, 1956). The rate of thermal decomposition of the oil, or the 'cracking temperature', was found to increase

rapidly above 600°F (Waddock, 1954, p.5). Additionally, any oil leakage into the high temperature compressor airflow could cause serious bleed air contamination of toxic fumes forming (Palsulich and Riedel, 1956).

The majority of cabin air contamination events had long been recognised as small leakages of synthetic oil leaking past the bearings and seals of the engine compressor into the bleed air (DAC, 1966; Walker, 1990; EASA, 2009). It was recognised that more could be done to eliminate the contamination at the source (Waddock, 1954).

Reports of air supply contamination have continued over the years, with the lubricants being the predominant source. Examples include military, airline, and manufacturer reports (Gaume, 1973; Montgomery et al., 1977; Cone, 1983; Buist, 1989). Manufacturer documentation, including service bulletins and information letters, highlight crew and passenger exposure to oil fumes within the cabin (Best and Michaelis, 2005; Michaelis, 2010). Airworthiness directives report oil fume incidents involving crew impairment, with the FAA highlighting an unsafe condition (CAA, 2001; FAA, 2004). EASA acknowledged that more serious fume events have recently been reported with the 'vast majority of these events' associated with abnormal leakage of engine or APU oil (EASA, 2009, p. 5).

A wide variety of fume events are reported, with 32% involving impairment (Michaelis, 2011). Aircraft mechanical records confirmed oil in 41 of 87 fume event reports (Murawski, 2011). Of 259 oil related fumes or smoke mandatory occurrence reports in 5 years, 51% confirmed oil leakage and 31% varying degrees of impairment (CAA, 2011). A Safety Investigation Bureau investigation found that of 663 air quality events, 27% reported impairment, with 56% described as oil, chemical, dirty socks, or burned (BFU, 2014).

A few selected other sources of bleed air contamination include: legal documents identifying repeat events on the same aircraft (Forames, 2011); insurance claims (Hinrichs, 2015); scientific committee confirmation of oil fume occurrences (COT, 2013); media reports (GCAQE, 2016); crew reports (EASA,

2011); position statements (BALPA, 2005; ECA, 2015) and published papers (Harper, 2005; Abou-Donia et al., 2013; de Boer et al., 2015).

2.1.2 Frequency and Under-reporting

It is often reported that the frequency of oil fume leakage is infrequent or extremely rare (ASHRAE, 2013; Day, 2015), with 'spurious' reports made due to worn seals or reservoir overfilling (Overfelt, 2012, p.1). However, oil fumes are reported by others to be common (Winder and Michaelis, 2005; Michaelis, 2010).

Documented bleed air contamination events range from 2.7 to 33 events per million aircraft departures (Day, 2015) to 2.1 events per 10,000 departures (Shehadi et al., 2015b). Pilots reported oil fumes in 1% of flights, subsequently confirmed by engineers in 0.05% of events (COT, 2007). However, it is commonly accepted that the reported frequency may under-estimate the reality due to under-reporting (FAA, 2006; Michaelis, 2010; Shehadi et al., 2015b).

EASA advised fume events remain relatively low with the more serious events involving crew impairment and incapacitation being rare. Lesser temporary bad smells due to maintenance or mechanical failures are under-reported with it "not possible to determine a reliable rate" of these events (EASA, 2009, p. 3).

Forty-three events of air supply contamination over four years were reported, while recognising not all events were reported to the manufacturer (Holley, 2009). Airbus reported that oil seal leakage from the APU was "extremely rare" and engine "even more rare", only occurring after a "very unlikely incident", explaining why no reliable data had been collected (Dechow and Nurcombe, 2005, p.19). The air conditioning and bleed air systems were subject to "a high number" of operational interruptions (Juan and Amsellem, 2012).

There are many sources supporting the regularity of fume events and the reasons for under-reporting. Oil contamination of the air supply from the APU or engines occurs "with some regularity" (AAIB, 2004, p.30), with the recurring nature leading to diminished understanding of the risks and events seen as routine (ATSB, 2003). Such events are neither new nor rare with under-

reporting recognised (BASI, 1997; PCA, 2000). Oil leaks and fumes were regarded as a nuisance, rather than a potential flight safety issue (BAe Systems, 2001a). Additionally, advice has been given that transient fume events, particularly after start, taxi and take-off are normal, hence need not be reported (Merron, 2007), and only fumes due to mechanical difficulty or failure require reporting (FAA, 2006). The lack of a flight deck warning of contaminated air events is also recognised as problematic (FAA, 2002; AAIB, 2009).

Another way of explaining the frequency recognises that seals may be less efficient during transients (BAe Systems, 2001b). A need to improve transient seal prediction was noted, given that sealing over the entire engine operating range is necessary (Peitsch, 2003). Low levels of oil leakage will occur with the current use of bleed air systems as the oil bearing seals will leak as a function of the design and operation of utilising oil seals reliant upon compressed air (Michaelis, 2011). This explains the frequency of oil fume events as distinct from the far more occasional failure scenario and avoids both the under-reporting and inaccurate reporting practice.

2.1.3 Exposure Data

A number of studies have been undertaken in recent years looking into the presence of an oil anti-wear additive organophosphate, tricresyl phosphate (TCP) and other oil related substances. Air conditioning ducts “were contaminated with a carbonaceous material containing chemicals entirely consistent with the pyrolysis products of aircraft engine oil” (CAA, 2004, p. vi). Numerous air monitoring studies have identified TCP between 25% and 100% of samples or flights (Crump et al., 2011; Houtzager et al., 2013; Rosenberger et al., 2013). The meta isomer of TCP was identified in 89-95% of HEPA filters (Eckels et al., 2014). The neurotoxic TCP isomer tri-ortho-cresyl phosphate (TOCP) was identified in 15% of samples and the EU REACH classified Substance of Very High Concern, trixylyl phosphate, was also found (Rosenberger et al., 2013; Rosenberger, 2014). A pilot partially incapacitated after fumes exposure was found to have TOCP in the blood (BFU, 2011). Furthermore, levels of TCP were reported to be higher during take-off, climb,

descent and during start-up. The majority of the studies reported no fumes were present during sampling, with TCP after an oil leak found an order of magnitude above normal operation levels (Solbu et al., 2011).

The organophosphates in the oil and other oil marker compounds are being routinely reported in normal flight and occasionally during low level fume events, with all levels reported as being very low and below available national and international health and safety guidelines, and not responsible for any reported health problems. The statistical probability of capturing a detectable fume event is said to be very low (Day, 2015; Shehadi et al., 2015b).

2.1.4 Safety

The implications of exposure to oil fumes upon flight safety is diverse. EASA suggests there is no safety case warranting action, as minor 'nuisance' events are not safety related as impairment or incapacitation is rare (EASA, 2011, p. 4). ICAO has highlighted the negative impact on safety when crew members experience acute symptoms due to oil, hydraulic fumes or smoke exposure (ICAO, 2015). IFALPA has recognised cabin air contamination can cause short-term health effects, which may compromise flight safety (IFALPA, 2013). Impairment in flight, related to oil fume events is widely recognised (AAIB, 2004, 2006; HOL, 2007; Michaelis, 2010; Murawski, 2011). Others accepting potential or actual flight safety implications from exposure include aircraft and engine manufacturers, regulators, government inquiries, industry committees, bureaus of air safety (BASI, 1997; FAA, 2004; SAE, 2005; Chaturvedi, 2009; Harrison, 2009; COT, 2013).

The German BFU reported marginal flight safety restrictions, yet recognised that impaired health and cabin crew performance occurred during fume events, while others caused harmless discomfort only (BFU, 2014).

2.1.5 Actions

Many initiatives have taken place over the last two decades as shown in Appendix A. These include government inquiries, conferences, regulator and scientific reviews. Two US public laws supporting research in areas of sensors,

mitigation technology, monitoring and a medical protocol have passed, however the later has not been funded, with work limited to a joint NASA, USAF and FAA study (US Congress, 2012; Day, 2015). A number of European consortium projects have been undertaken, with a standardisation initiative on air quality underway. Two Government sponsored studies into TCP are ongoing in Holland; Clean Sky has developed bleed free electric compressors, as used on the Boeing 787, and Future Sky includes a Cabin Air Quality (CAQ) oil fumes component.

A regulator study supported the term 'aircraft related illness' instead of 'Aerotoxic Syndrome' (EPAAQ, 2012, p. 146). EASA has undertaken an A-NPA and recently sponsored studies, on CAQ and oil pyrolysis characterisation. In 2015, ICAO published educational guidance on exposure to oil and hydraulic fumes and IATA published guidance for medical response to CAQ events. The UK COT committee has acknowledged that 'perceived' oil fume events are occurring in temporal relation with acute adverse effects, highlighting a safety concern (COT, 2013, p. 3).

Ongoing scientific studies include TCP toxicity, biomarker research, real-time sensors, filtration technologies and an exploration of health effects in aircrew.

2.1.6 Issues

There is 'general acceptance' that cabin air can be contaminated by compounds released from pyrolysed oil from engines and APUs (AAIB, 2013, p.3). Mobil considers this an abnormal event (Mackerer and Ladov, 2000). A variety of organic compounds are released when oils and their breakdown products enter the aircraft cabin, causing adverse effects on the air quality (NRC, 2002). Exposure to the oils, subject to temperatures of 500°C or greater may cause a multitude of adverse effects and a threat to safety (Chaturvedi, 2009).

There are three ways oil fume events are perceived: 1) failure condition but rare, 2) failure, operational or a feature of design but rare or 3) a feature of design. This is thereby integral to actions undertaken.

1) A common view is that oil fumes occur primarily, due to failure conditions:

- ‘Improper work or damage’ to the main shaft seals (Rosenberger et al., 2016, p.3);
- Seal failure on rare occasions (Boeing in HOL, 2007, p. 115);
- Minor systems failures involving oil leakage from the engine or APU (BAe in PCA, 2000, p.11);
- Rare mechanical failures (FAA in, Suppelsa, 2016);
- Unintentional oil, hydraulic or de-icing fluid leakage (NRC, 2002).

Airbus state that oil contaminants do not enter the cabin under normal operating conditions with ingress minimised after very unlikely failure conditions, providing no evidence of a systemic design failure (Dechow and Nurcombe, 2005; HOL, 2007, p. 101). It is commonly reported that the bleed air supply generally “operates as designed providing safe clean air to the cabin”, with contamination due to ‘accidental’ fluid ingestion occurring occasionally (Roberts et al., 2013). Examples often cited include worn mechanical seals or overfilled sumps (Overfelt et al., 2012).

2) A broader approach to oil leakage covers more than just the mechanical failure scenario, however the frequency is still said to be rare. The importance of bleed port and bearing design to reduce oil contamination is reported (DAC, 1966; SAE, 1981). Under certain fault conditions or episodic events such as engine or APU oil seal or bearing failure, maintenance error/irregularities, or design deficiency, oil may rarely contaminate the bleed air (EASA, 2009; ASHRAE, 2013).

3) Design factors related to using bleed air are less frequently discussed. Avoiding leakage out of the bearing chamber and into the main gas stream and the customer bleed off-take is the responsibility of the secondary air and oil systems groups (Peitsch, 2003). Ongoing design improvements of the bleed air off-take continue with seals being required to seal across the whole engine operating range, including during transient engine manoeuvres (Peitsch, 2003). “Every engine leaks oil from its seals and bearings”, (BAe in PCA, 1999, p.85) with such leaks a feature of the design of using the bleed air system (CASA in PCA, 2000, p.16). Oil seals that protect the air supply from contamination reach

maximum efficiency during steady state operation and may be less efficient during transients (engine acceleration, deceleration) or while the engine is still achieving optimum operating temperature and pressure (SAE, 2005). Improvements in seal design continue (BAe Systems, 2001b; Fox, 2012) and are recommended (ASHRAE, 2013).

Low-level oil leakage during normal flight is becoming more widely recognised, possibly explaining increased reporting, rather than reliance on failure or conditions only. Oil seal leakage is reported to occur during certain events such as engine switching, top of descent and in older aircraft, with chronic exposure to vapours that “continuously leak through the seals in ‘tiny’ amounts” (de Boer et al., 2015, p.558). This is supported by recognition that oil leaking from bearings can be either “slowly varying and somewhat continuous or sporadic and quite intermittent” (Overfelt and Jones, 2013, p.7). Background low levels of TCP are commonly reported in normal flights, along with low levels of other contaminants as shown in an ACER/ASHRAE study (Spengler et al., 2012).

This low-level leakage will occur with the current use of bleed air systems as the oil bearing seals will leak as a function of the design and operation of utilising oil seals reliant upon compressed air (Michaelis, 2010).

Lower-level leakage related to system design is often viewed as normal, safe and acceptable, associated with minor discomfort only, with increased levels due to wear or failure possibly affecting occupant health and flight safety (SAE, 2005). The events are said to range from the rare and serious smoke incidents to ‘simple dirty sock smells’ (Eckels et al., 2014, p.1), with improved seals leading to concentrations of oil in the bleed air being ‘negligible’ (SAE, 2005, p. 39). Another viewpoint, involves oil released from failed bearings and seals, normally being low in quantity, creating a nuisance rather than an operating or maintenance problem (SAE, 1981).

There are differing ways in which exposure to oil fumes are regarded. Boeing reports its “bleed air systems meet all applicable FAA requirements” and is safe based on current evidence (Boeing in Suppelsa, 2016). The Australian regulator, CASA suggests oil fume contaminants are more of an occupational

health and safety issue rather than an aviation safety issue (CASA in PCA, 2000, p.76).

An early manufacturer report suggested that it was 'doubtful' that the current methods used to ensure suitable bleed air purity certification would be suitable with future higher performing and higher temperature engines (DAC, 1966, p.2). It was assumed that the 'rather vague' FAA regulations would be made 'more stringent', necessitating a firmer basis for certification (DAC, 1966, p. 2).

The FAA reported that the lack of air contaminant monitoring systems meant that the aircraft design does not meet the intent of ventilation regulation 25.831 and that rulemaking has not kept up with public air quality expectations and protection against contaminant hazards (FAA, 2002). The adoption of existing air quality standards for aircraft was suggested. Airbus has also identified that the ventilation certification standards hardly, if at all, address the specific unique cabin environmental factors (Dechow and Nurcombe, 2005).

The link between exposures and effects is important as the various explanations help explain the thinking about oil leakage. Given the lack of epidemiology at the same time as monitoring of the air, symptoms may be related to other factors (Rayman, 2002). It is suggested that the symptoms experienced may be due to a nocebo effect or other factors given the low levels of one part of the oil additive found, TOCP (COT, 2013, p.3; de Ree et al., 2014). However symptoms reported have a biological plausibility (Spengler and Wilson, 2003). The symptoms are consistent with exposures to oil fumes, with low levels of individual substances possibly not a problem, but exposure to the mixture might be highly toxic (Chaturvedi, 2009, p.28). Increased toxicity of low dose exposure to mixtures is increasingly recognised, (IGHRC, 2009; Carvalho et al., 2014) along with individual susceptibility. Exposure to the oils and individual substances are clearly recognised as harmful and hazardous (Guerzoni, 1999; Boeing, 2007; European Commission, 2009; Harrison et al., 2009; Michaelis, 2010, pp.344–352 and 620–638; ExxonMobil, 2016b; ICSC, 2016).

Additionally, ground based safe exposure levels often used to justify acceptable exposures, should not be applied to the aircraft environment (SAE, 2005; Michaelis, 2011; ACGIH, 2015).

However exposure to chemicals are serious. Substances at low levels may show more subtle changes than those exhibiting pathology (de Ree et al., 2014; Hausherr et al., 2014). Rolls-Royce recognises that any oil leaking from an engine entering the customer off-take “is classified as HAZARDOUS” (Peitsch, 2003) and “oil vapours and coking smells are obnoxious at best and health hazards at worst to the customer” (NASA, 1995, p. vi).

Several other factors include the concerns that illness related to fume events could be disabling, therefore requiring minimisation (COT, 2013). Maintenance diagnostics have been referred to as being of a ‘trial and error’ nature (Overfelt et al., 2012, p.2) and failure to eliminate the source of the contamination will lead to repeated occurrences (Vera-barcelo, 2013). Additionally, the financial losses related to these events range from approximately \$40,000 per incident to \$2,000,000 per day (Fox, 2012; Shehadi et al., 2015a).

Given that oil is recognised to leak into the bleed air supply in a variety of ways, it is necessary to review applicable clean air certification standards.

2.2 Certification Standards

There are a variety of aircraft certification and other standards and Acceptable Means of Compliance (AMC) or guidance material relating to clean air requirements. These must be met at certification and on an ongoing basis. The US Federal Aviation Regulations (FAR) and European Certification Specifications (CS) standards are outlined below along with suggested non-mandatory AMC.

2.2.1 CS and FAR Standards and Guidance Material

2.2.1.1 Equipment and Systems Design - Airframe

CS 25.1309 and the FAR equivalent airframe airworthiness standards require equipment, systems and installations to be designed ensuring they perform their

intended functions under any foreseeable operating condition, including fluid or vapour contamination, according to the AMC,. The FAR require failures causing the prevention of safe flight and landing to be extremely improbable and reduced ability of the crew to cope with adverse operating conditions, improbable. The CS specifications utilise three categories including ‘hazardous’ failures, as extremely remote and ‘major’ failures as remote. See Appendix B for official wording of the CS and FAR and associated guidance AMC.

The compliance guidance, (AMC 25.1309, AC 25.1309-1A) while not mandatory, set out acceptable means of compliance. Each failure condition should have a probability that is inversely related to its severity as seen in Figure 1.

EASA AMC 25.1309

FAA AC 25.1309-1A

Figure 1: Relationship between Probability and Severity of Failure Condition Effects

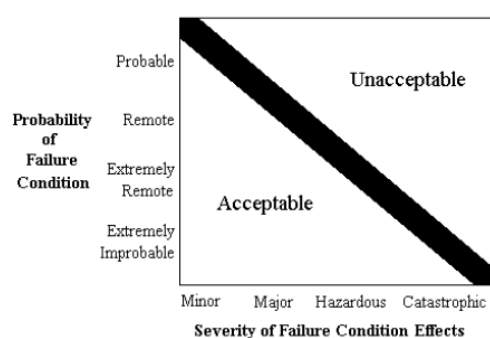

Figure 1: Probability vs. Consequence Graph

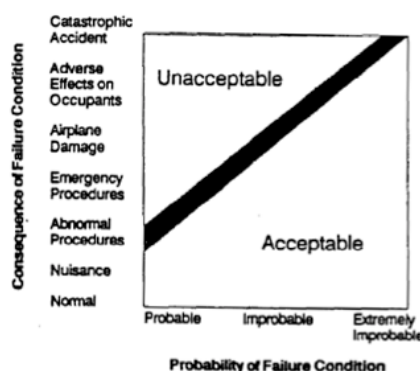

Figure 1: AMC - Probability vs Severity

Source: EASA AMC 25.1309 & FAA AC 25.1309-1A

As shown in Appendix B, the EU AMC describes major failure conditions as those that could impair crew efficiency, or cause physical discomfort to the pilots, or physical distress or injury to the passengers or cabin crew. Such conditions must be remote, unlikely to occur to each aeroplane during its total life, but may occur a few times during the total life of all aircraft of type, with average probability per flight hour of 10^{-5} or less but greater than 1×10^{-7} .

Figure 2 shows in detail the EASA CS 25.1309 AMC relationship between the probability and severity of failure conditions.

Warning information must be provided to alert the crew to unsafe system operating conditions and to enable them to take corrective action (FAR and CS 25.1309C).

Effect on Aeroplane	No effect on operational capabilities or safety	Slight reduction in functional capabilities or safety margins	Significant reduction in functional capabilities or safety margins	Large reduction in functional capabilities or safety margins	Normally with hull loss
Effect on Occupants excluding Flight Crew	Inconvenience	Physical discomfort	Physical distress, possibly including injuries	Serious or fatal injury to a small number of passengers or cabin crew	Multiple fatalities
Effect on Flight Crew	No effect on flight crew	Slight increase in workload	Physical discomfort or a significant increase in workload	Physical distress or excessive workload impairs ability to perform tasks	Fatalities or incapacitation
Allowable Qualitative Probability	No Probability Requirement	<---Probable--->	<---Remote--->	Extremely Remote	Extremely Improbable
Allowable Quantitative Probability: Average Probability per Flight Hour on the Order of:	No Probability Requirement	<10 ⁻³ Note 1	<10 ⁻⁵	<10 ⁻⁷	<10 ⁻⁹
Classification of Failure Conditions	No Safety Effect	<---Minor--->	<---Major--->	<---Hazardous--->	Catastrophic
<p>Note 1: A numerical probability range is provided here as a reference. The applicant is not required to perform a quantitative analysis, nor substantiate by such an analysis, that this numerical criteria has been met for Minor Failure Conditions. Current transport category aeroplane products are regarded as meeting this standard simply by using current commonly-accepted industry practice.</p>					

Figure 2: CS 25.1309 AMC: Probability vs Severity

Source: EASA AMC 25.1309

2.2.1.2 Safety Analysis - Engine and APU

A safety analysis of the engine is required under CS-E 510 and FAR 33.75, with acceptable means of compliance provided as shown in Appendix B.

Compressor bleed systems must be included in the safety analysis. Concentrations of toxic products in the engine bleed air for the cabin deemed sufficient to incapacitate crew or passengers are regarded as a 'hazardous' engine effect under the FAR or CS standard. These must be predicted to occur as extremely remote, at less than 10^{-7} per engine flight hour (/efh). 'Major' engine effects must be remote at less than 10^{-5} /efh, however further detail is not provided in the regulation/standard.

The guidance material lists 'hazardous' effects as including no effective means to prevent the flow of toxic products to crew or passenger compartments or toxic products impossible to detect or stop prior to incapacitation. Degradation of oil leaking into the compressor airflow is listed as a toxic product.

Concentrations of toxic products slow enough acting and/or readily detectable so as to be stopped prior to incapacitation are considered 'major' engine effects. These include substances sufficient to degrade crew performance.

CS-APU 210 safety analysis and its AMC are similar to CS-E 510, while a US APU Technical standing order (TSO-C77b) requires that failures do not generate an unacceptable concentration of toxic products in the bleed air.

As absolute proof of such low probabilities is not possible, reliance on engineering judgement, previous experience and sound design and testing is therefore acceptable.

Prior to the 2007 FAR 33.75 amendment, there was no requirement to review toxic bleed air components, while the 2001 JAR acceptable compliance referred to unacceptable concentrations of toxic products in the bleed air supplied to the cabin.

2.2.1.3 Bleed Air

CS-E 690 requires contamination or purity tests of the bleed air when it is directly used in the cabin. An analysis of the defects which could affect the purity of the bleed air must be prepared and where necessary defects must be

simulated and tests undertaken to establish the degree of contamination that is likely to occur.

The US FAR 33.66 for bleed air systems, requires engines to supply bleed air without adverse effect on the engine. FAR and CS 23.1111 require that bleed air systems do not allow hazardous contamination of the cabin air systems from failures of the lubrication system.

CS-APU 320 and TSO-C77b require that for APUs providing compressor bleed air, the characteristics of the bleed air contaminants will be listed.

2.2.1.4 Airworthiness - Ventilation and Heating

CS 25.831a requires that each crew compartment has enough fresh air enabling crew members to perform duties without undue discomfort or fatigue. FAR 25.831a is very similar but covers normal and probable failure conditions, uses the term 'sufficient amount of uncontaminated air' and references reasonable passenger comfort. 25.831b requires that the crew and passenger compartment air must be free of harmful or hazardous concentrations of gases or vapours. Only carbon monoxide, carbon dioxide levels and fresh airflow rates are listed.

2.2.1.5 Unsafe Condition

An unsafe condition includes events that occur more frequently than the safety objectives allow; that may reduce the ability of the crew to cope with adverse operating conditions, impair crew efficiency or cause discomfort/injuries to occupants (AMC 21.A.3B(b)).

2.2.2 Other Standards and Regulations

Historically, MIL-E-5007 specification was utilised as one form of certification guidance compliance. Oil leakage within engines was not to cause oil discharge upon starting after previous shutdown or cause contamination of the bleed air or deposits. A compressor bleed air analysis was to be undertaken to ensure contaminant levels were within specified limits, including oil breakdown

products. Additionally, the lubrication system must function properly under conditions in which the aircraft operates (FAR 33.71).

Other currently used voluntary standards include:

- SAE ARP 4418, Aerospace recommended practice lists a limited set of bleed air generated contaminants,
- SAE Aerospace Standard 5780A and previous MIL Spec, MIL-PRF-23699F for oils differ regarding the allowable effect on personnel,
- ASHRAE Standard 161-2013 and guideline - Air Quality within Aircraft.

The new EU occurrence reporting regulation requires contaminated air to be reported as well as any burning, smoke, fumes or leaking fluid (EU Regulation 376/2014; 2015/1018).

2.3 Oil System

The lubrication system provides oil to provide lubrication, cooling, corrosion protection and as a sealing medium itself. This self-contained re-circulatory dry sump oil system (see Appendix C), distributes oil to the components throughout the engine, with the oil returned to the oil tank via pumps to then repeat the cycle.

The oil system has three main sections, although specifics in particular engines will vary. A simplified theoretical explanation is detailed and shown in Appendix C. The oil supply system sends pressurised oil via supply pumps and heat exchangers, to the bearings in individual bearing chambers, gears, seals and splines. After completing the lubricating and cooling tasks, the oil is directed to sumps in each bearing chamber.

The scavenge systems consists of scavenge pumps, extracting the oil from the lubricated areas including each sump and returning it to the oil tank as quickly as possible. The flow returned to the tank is a mixture of oil and sealing system air. A de-aerator in the oil tank separates the oil from the air, with the air then vented overboard via the breather. If the oil was not removed from the sumps via the scavenge system, oil would be forced past the bearing oil seals into the

compressor. Such leakage could cause burning, and seal bearing malfunction (FAA, 2012a, p.vi).

Pressurised seals are utilised to prevent oil leakage from the bearing chambers and between rotating shafts. To ensure the pressure drop is always into the bearing chamber, the chamber normally provides a vent to a lower pressure. The vent system capacity ensures sealing air is sufficient to seal the bearing chambers, with minimal impact on engine performance. The air vented from the chambers contains oil, which is separated and retained in the system via a rotating air/oil separator or de-oiler (breather), with the air and a small amount of oil vented overboard.

It is critical that a minimal amount of oil is utilised to undertake its various functions and retained in the lubrication system. However, there is a stated permissible consumption of oil, usually 0.1 to 0.5 US quarts/hour per engine (Linke-Diesinger, 2008).

2.3.1 Oil bearing Chamber Sealing

Given the ongoing debate about how to interpret leakage of oil into the air supply, the literature for the oil sealing, bleed air systems and leakage will be reviewed.

This thesis will not attempt to take into account the specific differences in various engines, oil systems and bearing seals, which may be complex. Additionally the focus will be on oil leakage from engines and APU power sources, as distinct from other sources such as Environmental Control Systems (ECS), external sources and mechanical failures.

2.3.2 Secondary Air

Around 25% of the engine core airflow is extracted and utilised to supply engine internal air and various aircraft systems. This secondary air also known as bleed air, is primarily tapped off the compressor and used for cooling engine and accessory components, bearing chamber and oil cooling and sealing,

control of turbine tip clearances, cavity ventilation, control of bearing loads, cabin pressurisation, ventilation, anti-icing and other services.

The majority of secondary air is returned to the mainstream air after performing various sealing and cooling functions. Bleed air used for (customer) cabin pressurisation, and wing anti-icing, is vented overboard after use. A 1% reduction in secondary air extracted gives a 0.4% reduction in specific fuel consumption (SFC), (Chupp et al., 2006). The extracted secondary air is controlled and minimised as it reduces the power and efficiency of the engine (Johnson, 2010). To achieve this, a number of oil and air seals are required.

2.3.3 Oil Supply to Main Bearings

The use of gas turbine engines requiring synthetic oils, enabled aircraft engines to become more efficient and powerful, through higher engine temperatures and pressures (Johnson et al., 1952).

Oil is supplied under high pressure to all main shaft bearings. Internal air systems are very complex with careful review of the schematics required for each engine (Gunston, 2006).

The engine bearings, grouped in bearing chambers require a continuous supply and removal of oil. The oil has a number of functions including the requirement to lubricate and cool bearings in the bearing sump and to wash away metal particles released from the bearings and gears during normal operation (Linke-Diesinger, 2008). The oil must also support the sealing of a particular type of seal, the carbon bearing seal.

Ninety percent of the oil's function relates to heat transfer, 5-10% reduces friction and 2-3% is used for sealing, filter contaminants, and anti-corrosion (ExxonMobil, 2016a).

Oil seals are required to perform various functions including prevention of moisture and dirt entering, and the oil leaking out of the bearing chambers; control of air leakage to the bearing compartment and therefore improvement of engine performance; reduction of oil consumption; ability to operate under

normal and reverse pressures and they require a very long life (Tran and Haselbacher, 2004).

2.3.4 Bearing Compartment Sealing

Oil leakage outside the bearing sumps may result in performance loss due to contamination of aerodynamic parts, engine fires, vibration due to oil accumulation in rotating parts, or pollution of the air bleeds resulting in cabin air contamination (Whitlock, 1978; ExxonMobil, 2016a).

Pressurised air from the compressor (see Figures 3 and 4) is used to prevent oil leaking through the bearing oil seals and to cool and ventilate the bearing sumps to prevent the build up of combustible gas mixtures.

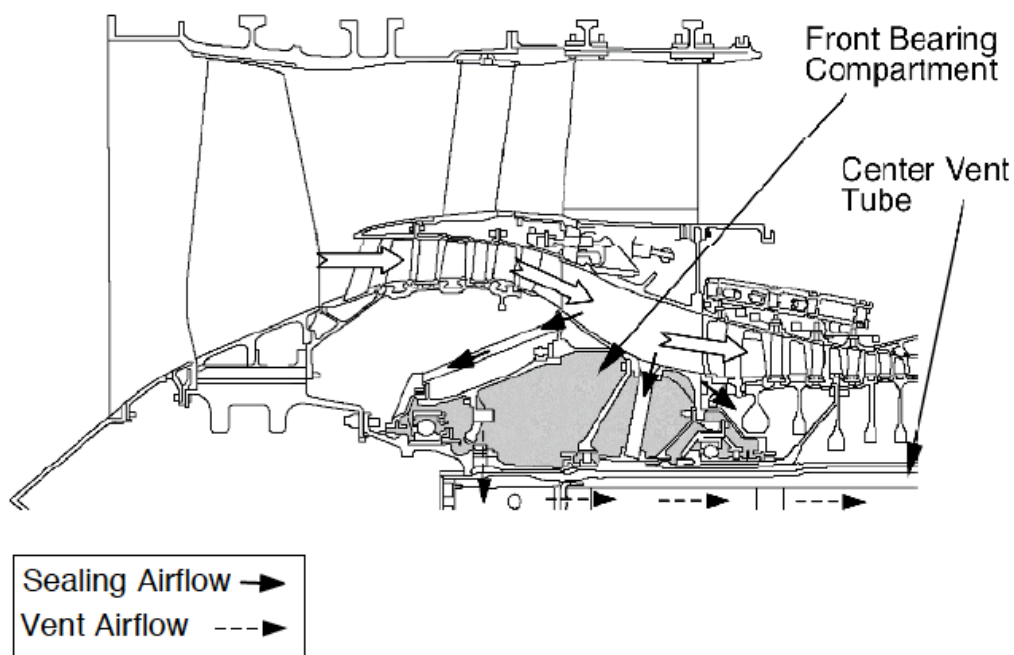

Figure 3: Bearing Compartment Pressurisation – CFM

Source: (Linke-Diesinger, 2008, p 28)

The philosophy behind engine bearing compartment sealing involves using pressurised air to maintain the bearing compartment at a lower pressure than its surroundings, therefore inducing an inward flow to prevent an outward oil leak

(Whitlock, 1978). The air is used to buffer the seals around the bearing chambers to prevent oil leakage, but too much airflow is a performance penalty and increases the heat load to the oil in the chamber (Rolls-Royce, 2005).

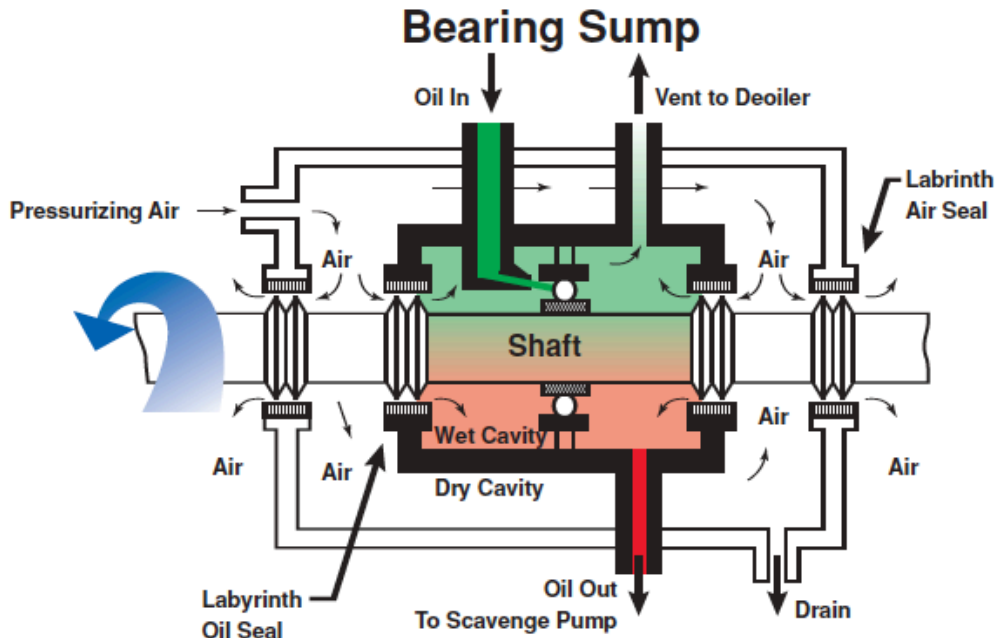

Figure 4: Oil Bearing Sump

Source: (ExxonMobil, 2016a)

The pressurised oil bearing seals are generally clearance labyrinth seals or mechanical contact face seals, both relying upon compressor pressurised air as part of the sealing function (Linke-Diesinger, 2008).

2.3.5 Bleed Air for Pressurisation and Ventilation

Military jet aircraft commenced using compressed bleed air for ventilation and pressurisation in the late 1940s. It was soon recognised that engine bleed air used for the ventilation was increasingly subject to unacceptable contamination, with the compressor bearing seals being the main source of oil leakage (Reddall, 1955). Early commercial jet aircraft, such as the Boeing 707, Douglas DC8 and Convair 880/990 drew air in from outside the aircraft using separate blowers or compressors. The direct use of bleed air bleed air for ventilation as

currently used on all civil jet aircraft (except for the Boeing 787), was introduced in the Sud Aviation SE210 Caravelle which first flew in 1955.

Bleed air oil contamination was seen as acceptable but somewhat contradictory. The secondary air often carried fine droplets or vapours of oil, with the use of turbo machines using outside air, as engine bleed air may contain minute traces of oil, however oil could not seep past the other side of labyrinth seals (Gunston, 2006). The use of outside ram air and associated systems were seen as the most positive solution, yet heavy, complex and expensive, as well as maintenance intensive and inefficient (Reddall, 1955; Marzolf in NRC, 2002, p64). Bleed air contaminated by engine oil was said to be non-toxic but ranged from an objectionable odour to severely irritating to the eyes, nose, throat and lungs (Reddall, 1955). Air extracted from the least contaminated section of the compressor was considered a marginal solution to the contamination problem, with future reduction in oil leakage making compressor air suitable for military aircraft but not commercial airliners, where odour free air was required (Reddall, 1955, p. 9). With jet aircraft flying at higher altitudes, larger equipment was needed to compress the outside air and as outside air was deemed to be of no discernable difference to bleed air, aircraft commenced using bleed air-based environmental control systems (ECS), (NRC, 2002, p. 64). Bleed air could become contaminated, yet studies undertaken in routine operations showed no contamination of concern with the air said to be clean and of excellent quality (Nagda et al., 2001; NRC, 2002).

Special precautions were undertaken to prevent oil leakage past the shaft bearing seals into the compressor inlet, with compressor bleed air deemed acceptable for breathing air in the occupied areas (Hauger et al., 1968). This was accomplished by taking the air from differing stages of the compressor and therefore limiting temperatures to which the air is heated and providing best economy. Larger engines mostly provide aircraft with both high and low pressure bleed air sources, with higher temperature and pressure air extracted at ground and flight idle.

2.3.6 Oil Bearing Seals

Given that engine compressor air is used for both pressurising the bearing sumps and supplying the cabin air along with use of synthetic oils, a review of oil bearing seals function is warranted. Differing descriptions of system leakage vary, from the oil cannot leak outside the sumps, most of the oil droplets within the oil system vent air are kept within the oil system (Linke-Diesinger, 2008) to small amounts will leak. An airline maintenance training manual (cannot be adequately cited for confidentiality reasons) reports an advantage of the pneumatic system is that the provision of “odour free air has no toxins in it – though it often becomes contaminated with aircraft oils etc. and smells” (Company A, no date).

Aero bearing seals are required to operate at high speeds necessitating either a well lubricated seal or one that operates with a clearance (Flitney, 2014).

Lubricating oil is utilised to reduce moving parts of the engine from touching each other during operation, therefore preventing wear, friction and heat. Oil wetted areas are only inside the bearing compartments and gearbox and the oil has no contact to rotor components outside these areas to the gas path (Linke-Diesinger, 2008). In order for this to occur the walls of the bearing compartments are sealed against the rotating shafts with the use of two key types of seals, the carbon and labyrinth seal. Compressor sealing air flowing across the seal into the bearing compartment is utilised regardless of the type of seals (Linke-Diesinger, 2008) and is responsive to variations in engine operating conditions (Palsulich and Riedel, 1956).

Sealing bearing compartments containing oil and gas mixtures at near ambient pressure is difficult (Chupp et al., 2010). The pressure difference between inside and outside the chamber is very small, as a larger difference would see the oil blown out of the breather. However, the small differential in transient modes provides a much greater chance of pressure reversal.

2.3.6.1 Labyrinth Seals

Non-contacting clearance labyrinth seals (Figures 5 and 6) consist of a series of circumferential strips of metal extending from the shaft to form a cascade of annular orifices (Boyce, 2012). They rely on a number of grooves (the labyrinth) divided by ridges with knife-edge crests or fins.

Labyrinth Seal Function

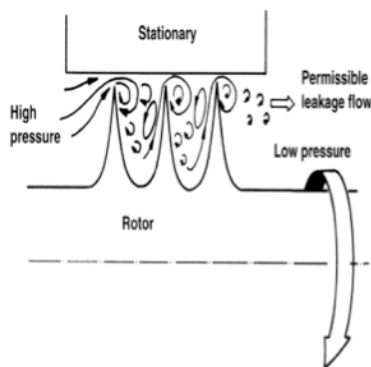

Source: Hunecke, K. 1997, Jet Engines

Fluid and Abradable Labyrinth Seal

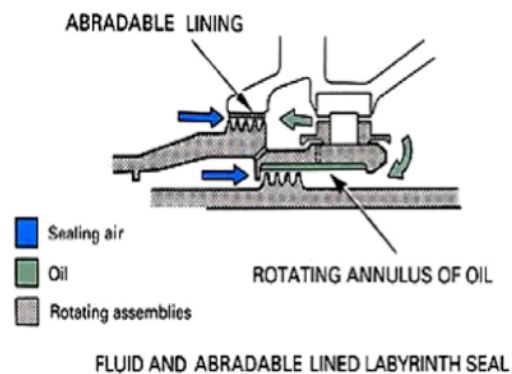

Source: Rolls-Royce Royce, 1986, The Jet engine

Figure 5: Labyrinth Seals Schematics

The stationary member incorporates a rub material that allows the rotating knife edges to cut into the stator, thus reducing the leakage of air over the seal and providing the required seal (Chupp et al., 2010). The stationary and rotating members rely upon a small tight clearance between them to reduce leakage flows, allowing an inward flow or controlled leakage of air, through a series of restrictions, followed by a clear volume creating expansion of the air and therefore reducing the pressure over the seal. This ‘torturous path’ of leaking air between high and low pressure regions restricts the leakage flow (ESDU, 2009, p. 9). It is commonly reported the pressure outside the seal is higher than the pressure inside the bearing chamber, therefore preventing the oil from leaking outwards. However any clearance permits fluid to flow in either direction, dependent on pressures and the momentum of the fluid (Childs, 2013, p. 566).

The clearance is set by aero-thermo-mechanical conditions allowing for rotor radial and axial excursions and minimising rotor contact with the shroud (Chupp et al., 2006). Adequate clearance to maintain sealing efficiency must take into account dynamic growth, thermal expansion, shaft motion and tolerance build-ups (Povinelli, 1975).



Source: (Idahospudsblog, 2014)



Source: Snecma Museum (2016)

Figure 6: Basics Of Labyrinth Sealing

Labyrinth seals have certain advantages including simplicity, low cost, reliability, good response to thermal variations, and reduced wear and friction. However, they are subject to high air leakage, loss of engine performance, tolerant to ingestion of particulates, which may damage parts, including bearings and do not in isolation provide a complete barrier to leakage (Flitney, 2007). Although good at restricting the airflow they do not respond well to dynamics, with permanent increases in seal clearances from shaft excursions on stop/start operations and other transient conditions (Chupp et al., 2006). Seal clearance also naturally increases with engine age due to rubbing under vibration, gyroscopic torque, rough landings or G-load factors (Ludwig, 1978a; ExxonMobil, 2014).

These seals lose performance fast with wear and when large clearances are dictated by transient thermal conditions (Ludwig, 1978a). Labyrinth seals, while used to prevent oil loss from the bearing compartment, would provide very poor sealing were it not for the high-speed inward airflow through the small clearance that sweeps the oil back into the compartment (Edge and Squires, 1969). However, the high leakage rates of hot gas (air) in to the bearing compartment tends to carry oil overboard (Ludwig, 1978b) and allows oil to leak out of the seal (Chupp et al., 2006). Given that labyrinth seals are clearance seals, there will always be some leakage across the seal from high to low pressure (Childs, 2013; Flitney, 2014). Simply put, the labyrinth seal is essentially a controlled leakage device (ESDU, 2002) relying on pressurisation to minimise oil leaking along the compressor shaft (FAA, 2012b).

2.3.6.2 Mechanical Contact Seals

Mechanical positive contact seals, such as carbon face seals form a seal between one stationary and one rotating flat precision-finished surfaces, preventing leakage (Boyce, 2012). The faces must have a high degree of flatness to form a good seal and must be lubricated so as to operate at a reasonable speed and provide a long life (Flitney, 2014). These are often used to seal bearing sumps, both restricting air leakage into the bearing sump and preventing oil vapours from passing from the sump into the cabin air stream (Chupp et al., 2010). However, this type of seal is more expensive, complex, and maintenance intensive; furthermore it has a shorter life than labyrinths (Povinelli, 1975; ESDU, 2002).

As shown in Figure 7, the faces are held in sealing contact, usually by a combination of the force of a spring and positive system pressure to ensure adequate loading of the carbon elements so as to minimise leakage and wear (Chupp et al., 2010). Gradual wear of the sealing faces occurs, extending service life of the seal and preventing shaft damage (Skewis, 2011). Other examples of factors affecting carbon seal performance include excessive wear of the faces during transients, (Chupp et al., 2010), finite rate of wear (Edge and Squires, 1969) and accumulation of coked oil deposits (Povinelli, 1975).

Mechanical carbon compressor oil seals are designed around the principle of forcing a small amount of seal oil across the flat faces, which are sandwiched between the rotating seal ring and the stationary sleeve. These are liquid seals designed to minimise the amount of seal oil that passes into the compressor (Wilcox, 2000). This minimal film of oil, typically below 1 μm thick, distributed between the flat faces, is a compromise ensuring the oil film is sufficiently thick. Thus providing adequate lubrication of the seal and long seal life, keeping it as thin as possible and minimizing leakage (Flitney, 2007). It is accepted that a normal seal will leak a very small amount of oil vapour from a few ppm to 10cc/min (Boyce, 2012). Increased speed and small increases in clearance between the faces can cause higher oil leakage over the seal.

Carbon Face Seal

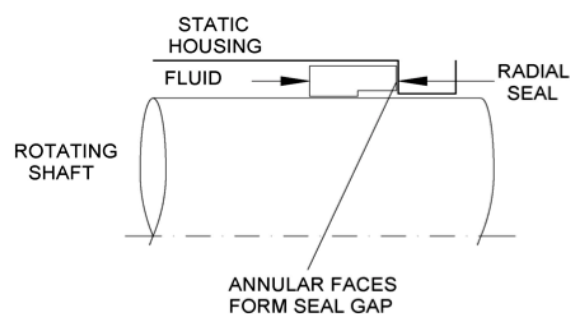
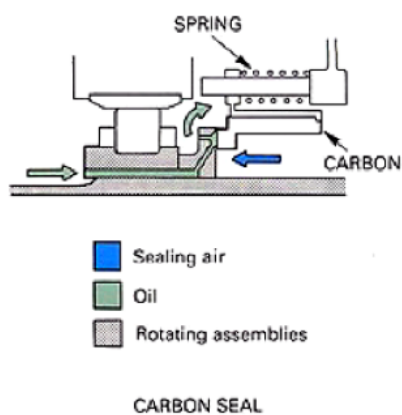

Source: (Rolls-Royce, 2005)

Source: (Childs, 2013)



Radial Carbon Face Seal. Source: Kaydon Ring & Seal. Aerospace Carbon Seals For Turbine Engines. Kaydon Ring & Seal, Inc.

Figure 7: Mechanical Carbon Face Seals

The flat faces, providing the seal, will distort with thermal and pressure effects and may encourage increased oil between the faces then pumped out to the air high-pressure side of the seal (Flitney, 2014).

Other features may be utilised to help prevent oil leakage. Basic labyrinth seals may be used as an adjunct to primary (face) seals, (Boyce, 2012) to assist preventing the oil passing into the compressor and prevent excessive leakage should the face seal open up (Chupp et al., 2006). A positive shutdown device may attempt to maintain air pressure when the compressor is at rest and the oil between the faces is not available (Boyce, 2012).

Labyrinth and mechanical contact seals are noted to have high and moderate air leakage, high oil consumption and oil pollution in the cabin with reverse pressures (Tran and Haselbacher, 2004).

Self-acting mechanical seals, a form of dry gas seal, have been suggested for use in aero engines (Ludwig, 1978b; Tran and Haselbacher, 2004). Benefits as shown in Appendix D, include no oil leakage with reverse pressures, reduced air leakage giving low oil consumption and no oil pollution (Tran and Haselbacher, 2004).

2.3.7 Common Aspects of Oil Bearing Seal Operation

The fundamental assumption for bearing seals is that the air in the compressor gas path will be at a higher pressure than the oil in the bearing chamber, thus causing leakage to always be into the bearing housing and not out into the gas path. ExxonMobil reports for seals to remain leak free, the pressure must always remain lower inside than outside the chamber (ExxonMobil, 2016a). It is commonly reported that oil seals only leak when a failure occurs. It is also stated that reverse pressures must be avoided with labyrinth seals to prevent high oil loss, while positive pressures will prevent oil leakage (Ludwig, 1978a; ExxonMobil, 2016a). However, the literature suggests this is not always the case.

Despite reliance upon positive pressure gradients preventing oil (leakage) flowing in the opposite direction, it is reported that oil may flow against this

positive pressure gradient with both types of seals, that is from low to high pressure. The positive gradient is difficult to obtain under all operating conditions and not a guarantee of zero oil leakage, and sealing bearing compartments at near ambient pressure is difficult (Palsulich and Riedel, 1956; Chupp et al., 2010).

Early research showed that pressures generated in the oil film between the mechanical face seals can cause liquid in the film to overcome the pressure gradient and leak both with and against the pressure gradient (Nau, 1964; Flitney, 2014). Dalton's law of partial pressures (Figure 8) in which a gas tries to create a constant partial pressure, indicates that high pressure air will not actually prevent oil vapour from permeating through the labyrinth against the pressure gradient (Flitney, 2014).

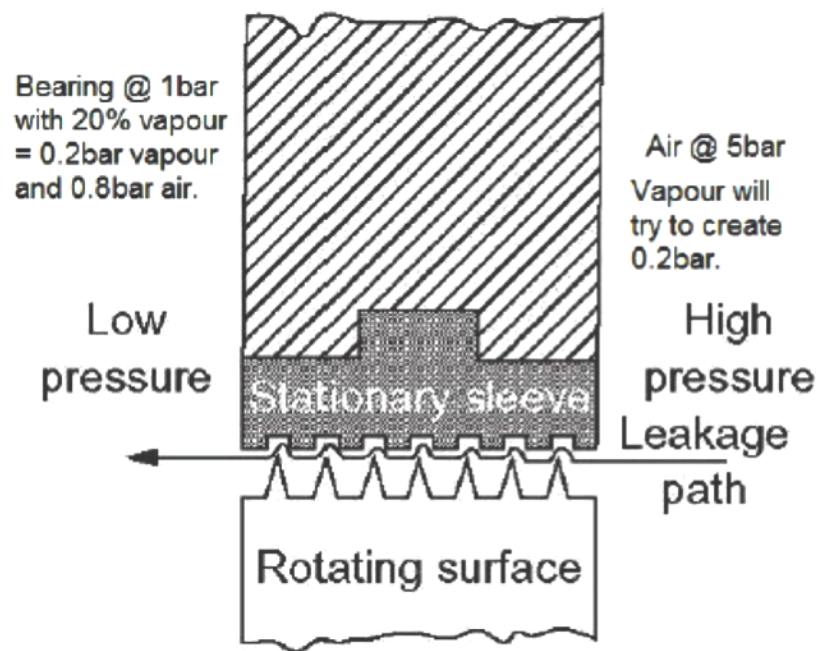

Figure 8: Partial Pressures Causing Vapour Leakage against Pressure Gradient.

Source: (Flitney, 2014)

In the case of reverse pressures over the seal during engine operation causing higher pressure on the oil side of the bearing chamber, both labyrinth and mechanical face seals will allow leakage in the opposite direction (Flitney, 2014). Labyrinths relying upon a clearance provide the explanation for leakage

with reverse pressures. The volume of leakage would depend on the seal design, clearance and pressure differential across the seal, with a face seal allowing considerable leakage should the face open with the reverse pressure, unless taken into account at the design stage (Flitney, 2014).

SAE reports oil leakage may be increased at various phases of operation including engine/APU start with seals not at operational pressure or temperatures and transients. “Some systems rely upon internal pressure to maintain the sealing interface, which may open up on shut-down allowing some oil to exit the oil wetted side of the seal. Upon start-up, the oil will be entrained into the air entering the compressor, with the seal interface again established once the engine internal pressure returns to operating norms” (SAE, 2005, p. 24).

Just about all known seals will leak, with seals designed to limit leakage and no such thing as a seal that does not leak, even if a very small amount, perhaps an emission rather than leakage (Flitney, 2014). “A Zero leakage seal is an oxymoron” (Chup et al., 2006, p. 29). Only very small amounts of oil need to leak to generate a noticeable cabin odour (Vera-barcelo, 2013) and it will be possible to smell oil before high oil consumption is noticed (SHK, 2001).

Further support of oil leakage over the seals in normal operations exists. Scavenged oil flow is lower than the supply flow due to normal oil consumption through the deoiler, oil seals and oil leakage. Higher oil consumption without apparent oil leaks depends on the efficiency of the de-oiler and the oil system seals (ExxonMobil, 2014). As the bearing compartment seals suffer increased wear, increased sealing air passes over the seal. This results in higher vent air flows and reduced efficiency of the de-oiler, increasing oil consumption and leakage as wear increases (Linke-Diesinger, 2008). Overall seal life is affected by transients and excursions outside design limits (ESDU, 2002).

2.3.8 Awareness of Oil Bearing Seal Leakage

Industry awareness of seal leakage is well established with limited examples below. This supports the general view that mechanical and labyrinth seals will

leak as a part of their normal function, along with the need for more advanced seals.

- The design of oil seals can contribute to oil contamination as they vary in effectiveness at different stages of aircraft operation, especially during transient stages of operation, that is take-off, landing or significant changes in altitude (EPAAQ, 2012).
- “Garrett and British Aerospace disagree with Ansett’s suggestion that a carbon seal will always leak a small amount” (NSWDDT, 2009, p. 32).
- Biggest seals technical challenge relates to low leakage and long life at high temperature and speed (Proctor, 2006).
- “Shaft seals - must function as SEALS – NOT flow restrictors” (Bill, 1991, p. 78).
- A consortium developed to improve face seal reliability as “Air oil/seals must be improved now!” (Ullah, 1995, p. 315). High temperatures in seals, incorrect tracking and oil coking causing leakage of oil and air, smell of oil in the cabin, high oil consumption and wear. Future research needs include the transient behaviour of seals.
- Seals capable of accommodating high misalignment, high rubbing speeds, low pressure differentials and large diameters must be developed for future engines (Shaughnessy and Dobek, 2005).
- “Carbon face seals are the industry workhorse but have problems with face blisters” (NASA, 1999, p.iii).
- “Conventional seals used to isolate oil vapours from cabin air do not have sufficient life to meet the current oil-free environment standard” (Thompson, R; Hagshenas, 2006, p.3).
- Sump evacuation system to reduce oil leakage from bearing sump (Przytulski et al., 2013).
- Oil smells in cabins are considered “unacceptable to the paying customer” and usually occurring after the aircraft is in service (NASA, 1995, p. viii).

- Evaporation loss of oil “constitutes only a minor part of the oil consumption in Rolls-Royce gas turbines, the major part of the consumption representing loss of liquid oil arising from permissible leakage past certain seals, escape of mist or aerosol through breathers” and losses incurred during inspections. These are made good by ‘topping up’ the system with fresh oil” (Edge and Squires, 1969, p.1575).

2.3.9 Choice of Bearing Seals

The actual bearing seal arrangements are complex, differing widely with specific engine design details not publicly available. The selection of one type of seal over another involves the acceptance of advantages and penalties, the magnitude of which varies with the specific engine design (Povinelli, 1975; ESDU, 2002).

Besides the simplicity and cost effectiveness of labyrinths, there are a wide variety of other factors determining which seals are used. For example, carbon face seals have ten times less air leakage, along with lower oil consumption (Povinelli, 1975) and are generally used in hotter parts of the engine (Edge and Squires, 1969). Performance penalties associated with higher air leakage into labyrinths are more problematic for smaller engines (Ludwig, 1978a).

There appears to be contradictory reports on which seals are optimal for sealing the bearing compartment. Both labyrinth and/or carbon seals are said to commonly seal the bearing oil sumps. Labyrinth seals are widely used for sealing of the air system (Rolls-Royce, 2005) and an effective oil seal, yet ignorance of the transient effects on the seal are reported (Whitlock, 1978). Carbon seals are said to be more effective for bearing compartment sealing, preventing oil leaking into the cabin (Rolls-Royce, 2005; Chupp et al., 2010). Conversion from labyrinths to other types of seals due to higher leakage rates are suggested (Peitsch, 2003; Boyce, 2012), however labyrinths will be around for a long time (Hendricks, 1995). Original Equipment Manufacturers (OEMs) have been satisfied with labyrinths for main shaft sealing despite mechanical seals suggested to be ‘seals of the future’ for aircraft engines (Hendricks, 1993, p. 72).

Some other factors to consider are: capability to absorb performance penalties associated with labyrinths, face seals being associated with excessive wear during transients and labyrinth seals enabling oil transport out of the seal (Chupp et al., 2010, p.997). The need for special arrangements to guard against 'toxic/hazardous' fluid leakage with mechanical seals is common practice (ESDU, 2002, p.12). However, the use of secondary sealing practices with aero engines is unknown. Single (mechanical) seals appear to be utilised, (Flitney, 2014) with some engines not using labyrinth seals to pre-seal and back-up carbon seals (SHK, 2001).

The problems associated with conventional oil sealing were clearly highlighted (AGARD, 1978). Shaft sealing gases and liquids was viewed as a significant problem, (Smith, 1978) and was not well understood (Dino, 1978). Seal technology had not kept pace with the advances achieved in the major components of the engines (Stocker, 1978). Given the increases in engine temperatures and pressures, shaft sealing technology was seen as "barely adequate for current needs" (Ludwig, 1978b, p. 16–2) and involving 'fire-fighting nature' research (AGARD, 1978, p. xii).

To address some of the concerns, seal design was recommended to be thoroughly integrated into the engine design process (AGARD, 1978, p. ix). Development of bearings and seals for the future must be done "well in advance of the establishment of engine specific requirements" (Povinelli, 1975, p. 273). The determination of which seals are causing problems is difficult unless there is complete seal failure or obvious damage, with on-condition maintenance and an inability to remove engines at low hours to refurbish multiple seal deterioration (Smith, 1978).

Advanced seals are being developed to reduce leakage, improve life and offer wider operating conditions than available for conventional seals (Chupp et al., 2006). Brush seals may reduce air leakage 50% and accommodate shaft excursions and other transient conditions. Advancements with face seals and transients have been made, while the labyrinth seal is reported to have improved over the years (Boyce, 2012; Wensheng et al., 2015).

2.3.10 Fluid Leakage Controls

Control measures in part depend upon how leakage is regarded. The aviation industry is seen as unique, in that environmental aspects drive sealing requirements as opposed to regulatory emission limits as occurs in critical industries, and the general environment (Hendricks, 1993). Customer satisfaction free of cabin smells and performance parameters drive aerospace sealing technology (Hendricks, 1993; Chupp et al., 2006). Where emission limits apply, single, double or tandem seals may be utilised, however few limits apply to the aerospace industry where leakage may be defined as 10,000 ppm or as a visible mist (Hendricks, 1993).

Higher performing gas turbine engines and the drive for improved SFC have necessitated greater sealing efficiencies to prevent increased performance losses (AGARD, 1978, p. ix; Stocker, 1978). The literature strongly reports on leakage paths, generally referring to minimisation of airflow leakage (Hendricks, 1995; Childs, 2005; Flitney, 2014) into the various components including bearing chambers, so as to reduce performance penalties. However there are only minor references to air/oil leakage out of the bearing chambers. In other cases, the requirement for advanced seal performance refers to improved main shaft air/oil seals, however details specific to oil leakage are absent (Mayhew, 1995).

2.3.11 Oil Leakage Under Normal or Failure Conditions

There are conflicting views about when oil leakage is likely to occur both in the normal and abnormal/failure situations. As shown, lower level leakage is expected under a range of circumstances. Reference to oil seal failure is more limited; despite it often said that oil leaks occur due to seal failures. There are increasing statements about design limitations, yet with little detail to back up these statements. The following statement appears to refer to failure, design and operation: Oil seal failures are driven by thermal gradient fatigue, axial and radial thermal expansions during maximum power excursions. Bearing compartment carbon seals fail from heat generated in frictional rub, whereas excessive carbon face wear occurs during transients (Chupp et al., 2010).

There is limited further information regarding oil leakage at varying stages of normal flight. Seals for aerospace are far more demanding than industrial applications, given frequent speed changes, seal operation at high altitude, start-up and shut down (Zheng and Berard, 2001). For example, full flow oil systems allow changing oil pressure with changing shaft speeds (Linke-Diesinger, 2008). Several sources allowing oil to leak from the main seals into the air include (Davidson, 2014):

- Misalignment of shafts and bearings before engine stabilisation;
- Rapid advancement of throttles not allowing giving time for seals time to settle into a proper sealing configuration;
- Autothrottle adjustments cause constant acceleration/deceleration of engines, resulting in changing compressor loads on seal assemblies, stress on the system allowing oil leakage and seal wear.

Incorrect equipment in combination with seal selection will give poor seal performance, regardless of the seal or arrangement selected (Boyce, 2012).

2.4 Summary

The literature supports the view that exposure to oil fumes continues despite global initiatives to address this. The frequency and understanding varies from the common position of infrequent occurrences with oil seal failure through to the less common view of frequent low-level leakage in normal operations as a function of design or a combination. The review of oil bearing seal operation supports low-level oil leakage during normal operations, combined with various operational factors with far less reference to the rarer failure scenario.

Certification standards for clean air do exist and given the disparity in views and strong supporting literature regarding oil seal operation, research questions are raised addressing how the regulators in practice ensure clean air and engineering experts understanding of seal operation. An analysis of the research questions will determine if there is a gap between the theoretical and practical understanding of compressor oil seal leakage and clean air and the existing certification standards utilised.

3 METHODOLOGY

3.1 Purpose of Research

The purpose of this research was to assess whether there is any gap between the transport category aircraft certification requirements for the provision of clean air in crew and passenger compartments and the theoretical and practical implementation of the requirements using the aircraft bleed air system.

While there are a number of regulations related to the ventilation air provided to the cabin and bleed air usage, there is a discrepancy in the theoretical and documented understanding of how engine oil may contaminate the air supply when utilising the bleed air system. Therefore, it was decided to focus further research on assessing the real world implementation of the certification requirements requiring clean bleed air. In order to understand how the certification process is undertaken in practice and how oil may contaminate the aircraft bleed air supply, two separate interview processes were utilised.

3.2 Data Collection Method

Data for the literature review identifying certification and other standards and the current documented understanding of how the conditions within the bleed air system may contaminate the aircraft breathing air supply, consisted of an extensive review of the literature. This was necessary as two of the research objectives were required to be identified via the literature review in order to address the overall aim, identifying if there is a gap between the requirements for clean air and theoretical documented and practical implementation.

The review consisted of looking at various databases and already known literature, utilising a number of terms including: bleed air, CAQ, cabin air contamination, synthetic jet lubricants, jet oils, oil bearing seals, bearing chamber sealing, labyrinth and mechanical carbon seals, secondary air, TCP, aerotoxic syndrome and aircraft systems. An analysis of the content and related themes was undertaken.

To answer the current research questions applicable to this thesis, the interview method was deemed the most suitable.

A semi structured mixed interview technique enabled the use of specific written questions allowing the respondent to answer providing an open ended response based on their expert opinion, followed where necessary with oral discussion to gain a further understanding. This qualitative approach enabled the respondent greater flexibility, while also ensuring a specific framework (Robson, 2002). The open-ended questions, allowed greater depth response, which could be examined further on follow up oral probing, for additional explanation or clarification.

EASA and the FAA were selected as the regulatory authorities to interview, as many countries utilise the EASA and FAA certification and type certificate process or use essentially the same standards when undertaking their own certification. The email based written questions and follow up oral telephone interview related to their professional understanding of the process by which they certify and ensure clean aircraft air requirements with the use of bleed air. The questions were directed to the engine propulsion and airworthiness departments as the lead department to answer the specific questions. The questions could either be forwarded on to the specific responsible areas, such as engines, APU, airframe or a specific regulation sector for responses or collated as one, before their return. Follow up where required, was undertaken with either the nominated person or specified expert.

Ten aviation engineering professionals and two seal supplier experts were selected to undertake the interviews involving their professional judgment on how oil may leak past oil bearing seals into the air supply under various flight operational conditions. The respondents were identified based upon professional contact with the researcher due to the researcher's previous expertise in this area (Michaelis, 2010). All were required to have extensive relevant aviation expertise and hold or have held senior positions within the industry. The experts selected were based in four countries in three continents.

In both cases, the written interview email based questions, sent in a de-identified word document format, was considered advantageous. This allowed for a small number of closely related questions to be asked, allowing the respondents time to obtain accurate responses or give thought to answers so as to provide suitable detail. Further follow up clarification or amplification of the responses could then be sought by telephone interview. The oral follow up could be as reasonably unstructured or in-depth as required.

Written answers provided were collated, with notes taken for oral interviews before transferring both formats to an excel database. Advantages of this format include cost and time efficiency, and allowed a global range of participants with significant expertise to participate. Furthermore, as this is a very specific area of expertise, time to provide succinct responses in the written format aided analysis.

3.3 Ethical Considerations

All responses provided were granted anonymity by the researcher and with the use of a consent form outlining conditions of participation. The written questions were preceded by an introduction including reference to the consent form. The form along with oral interview notes use a participant number and are unidentifiable with any individual. Additionally the researcher was granted ethics approval by the Cranfield University CURES system.

3.4 Development of Interview Questions

The questions raised with both the regulators and the engineers were based upon the research identified in the literature review. The regulators were asked about the practical process of certification and compliance in relation to clean air supply requirements utilising the standards identified previously. Given the differing understanding of how oil may leak past the bearing seals into the cabin air supply, the engineers were asked about their professional view and conditions under which this may occur.

The regulators and engineers were asked seven and eight written questions respectively. The questions to each group were identical; however follow up oral

questioning, based on the initial written interview questions, allowed greater flexibility. The open ended nature of the responses made analysis more challenging, than for closed type questions.

3.5 Data Analysis

The analysis of both of the interview groups' qualitative responses utilised a simplified thematic coding approach using excel. This is suitable for qualitative analysis (Robson, 2002). The data acquired was partially coded to identify points of interest with the same codes grouped together to form a theme then used for further data analysis and interpretation.

3.6 Validity

After preparation of the interview questions, the researcher undertook a review utilising data gathered in the literature review to verify credibility of the questions. The literature review utilised two areas of data. The first being the available standards related directly or indirectly to bleed air purity. The second being an understanding of oil leakage into the air supply based upon broad aviation industry understanding and documentation from those directly involved in the relevant areas in an engineering capacity.

Each question was reviewed to ensure the question was valid in terms of: credibility, validity, clarity, time required to respond and therefore completeness of data, logical flow of questions and language.

Interpretation of the interviews was crucial and therefore care was taken to ensure a framework was not placed on the data. Rather the data generated the themes and subsequent analysis and the data was checked regarding representativeness and consistency. The categories identified during the analysis were compared with the answers provided by the respondents to ensure validity of the research.

Other aspects considered were lack of respondent bias, prolonged association enhancing credibility and quality of data, verification of data with respondent, search for negative cases and audit trail of interview raw data.

3.7 Limitations

The area of research is understood by the researcher to be highly specialised and not understood by the wider audience, with therefore a natural reluctance by many to engage in discussion on this area. Hence, a willingness to participate in this research could not be guaranteed. By addressing the regulatory and engineering aspects only of the clean air requirements and identifying specialists with varying views, (who were aware of the researcher's earlier activities), participation in a current aviation global topic was well accepted. Further, the researcher approached the regulatory authorities to identify the specific area required and seek their support and participation.

By sending out a set of interview questions by email, it was possible that the email with word document attached could end up in the spam inbox. It was therefore necessary to follow up with the participants after sending the email to ensure it was received. Additionally, there was the potential that the respondents would not take the time to provide comprehensive responses, however, given the preliminary request for participation by a small group of experts on a current topic, thoughtful responses were expected.

4 DEVELOPMENT AND RESULTS OF INTERVIEWS

4.1 Engineers

4.1.1 General

In order to address the practical implementation of providing clean air to crew and passenger compartments, a group of experienced engineers and seal experts were selected to provide their understanding of how oil may leak internally within the engines.

4.1.2 Demographics

Ten engineering professionals specialising in gas turbine engines, were selected along with two seal experts. Ten of the twelve participants had spent an average of forty-three years in their respective fields, with the remaining two averaging thirteen years. Their expertise, specific to turbine engines and or seals included mechanical engineers, gas turbine designers and technicians and licensed aircraft maintenance engineers. Six participants were from the UK, two from the US, three from Australia and one from France.

4.1.3 Interview Objectives

The overall aim of the interview was to assess the practical understanding of professional engineering experts regarding oil leakage past oil bearing seals into the compressor bleed air supply.

The interviews consisted of written questions with telephone follow up as required. All questions bar the first, related to oil leaking past compressor oil bearing seals.

4.1.4 Limitations

By asking the questions in a qualitative manner, the respondents answered in more ways than one. While some response rates on various comments were low, this was due to a number of factors, including responses being

- categorised in narrow categories to ensure detail not lost in specialist area;

- similar comments provided in variety of ways and part of broader category, enabling retention of detail to provide an adequate understanding;
- qualitative format requiring greater time expended therefore limiting individual detailed response covering all areas, yet comments provide comprehensive overall picture and greater benefit than quantitative format;
- indicative of highly specialised area with experts demonstrating knowledge within their specific area, rather than few supporting particular view.

Overall the response rates were high with failure to respond cases relating to questions being outside area of expertise. The responses provided, highlight an overall picture and while broader categories could have been used to capture higher response rates, this approach would have lost the detail and not helped provide a comprehensive understanding.

4.1.5 Analysis of Results

An analysis of the results are outlined in the questions below:

QUESTION 1: What areas can oil leaking out of the engine or APU bearing chamber go?		
	Answer (11 out of the 12 respondents answered this question in the following ways)	No.
1	Leakage can be either external or internal to the engine or APU	2
1a	External leaks - into compressor inlet	1
1b	Internal leakage can be confined to the oil system or be out of the oil system	1
1c	Oil system breather exit	5
2	Internal oil leakage past seals	11
2a	Past main gas path seals into core main flow - turbine or compressor	7
2b	Past LP & HP compressor seals & APU load compressor seals, into compressor core main flow, cabin bleed air	4

2c	Core main flow then compressor/bleed air system via high/low stage bleed valve (cabin) or exhaust	9
2d	Allowable oil leakage (within limits) from forward bearings into compressor/other areas	1
2e	Bleed air system/ECS/engine bleed air start system	1
2f	Oil accumulates in cavities/components in engine & can be released into gas path	3
2g	Any secondary air flow paths	3
2h	Anywhere within the engine core or secondary airflow paths	2
3	Other	
3a	Various - Nose cone anti-ice, drains, access points, pipe connections, gearbox	3
3b	APU oil leakage into air inlet plenum, then into compressor/bleed air	3

Although this question focused on all leakage paths outside the bearing chamber, the respondents focused on internal leakage past engine oil seals in the compressor. However, the responses provided indicate oil leakage can occur within and outside the engine along with normal oil consumption as part of the oil system via the aircraft breather. There was clear recognition that internal oil leakage from the compressor bearing chamber can allow oil to enter the core flow with potential to enter the cabin bleed air system.

QUESTION 2: What are the factors that may allow oil to leak past compressor bearing seals?

	ANSWER (12 of the 12 respondents answered this question in the following ways)	No.
1	Labyrinth and carbon face seal usage will leak as not absolute designs	5
1a	Labyrinth seals rely on clearance/pressure differential. Carbon face seals rely on physical contact and are designed to have leakage rate as provides lubrication within seal	3
2	Leakage of seals affected by speed and rotation of engine/power/phase of flight	3
3	Material technology, quality control production design limits and design application effect seal performance	1
4	Thermal and axial/radial changes in engine structure effect gaps needing	6

	to be sealed	
4a	Seal effectiveness depends on dimensions/tolerances in assembly and application conditions – gap can be larger if tolerances not quite right but still within limits	2
4b	Thermal expansion - shaft and seal made of differing materials, therefore expand at different rates. Increased gap causes loss of efficiency of seal/leakage	2
4c	Changing power/loads on shaft changes clearance and load on seals/oil leaks into cavities around engine (difficult to find) and released on changing airflow/moisture into core airflow.	1
5	Pressure differential around seal (varies at different stages of flight) must be enough to stop oil migrating over seal	8
6	Failed shaft seals/rare with proper maintenance	2
7	Seal wear/component deterioration	11
7a	Increased seal wear/degradation due to age of seals; higher than normal oil operating temps; carbonisation; misalignment; imbalance in rotating shafts	9
7b	Carbon seals are contact seals with wear expected	6
7c	Oil leakage of the engine compressor seal caused by normal wear during expected on-wing life is rare	2
7d	Failing bearing effecting alignment of seal	2
7e	Insufficient warm up – Non-stabilised temperature gradient interface with seals and mating surface pressure	2
7f	Damaged seals	1
7g	Degradation of seal compound	1
7h	If oil is decreased in certain areas, higher operating temperatures occur with hot gases able to go where should not - less efficiency on seal	1
8	On condition maintenance	5
8a	Extended life of components/hours on wing/modular changes - increased wear and on condition maintenance regulations not specific to looking at seals at various maintenance checks which are up to operator	4
8b	Extended component life - lose some buffering air/efficiency. Identified on test bed configuration	1
9	Seals - incorrectly installed/maintained	4
10	Oil contamination	1
11	Oil not compatible with seal components	1

12	Design parameters that do not take all possible ambient and flight conditions into account	4
12a	Designs modelled for steady state (SS) conditions only as cannot model for transients. Leaks identified by inspection	1
12b	Transient leaks not recorded	1
12c	Oil sealing system for engines is impressive. Manufacturers view little can be done to improve design	1
12d	FADEC (Full Authority Digital Engine Control) - Engines chase airspeed/changing power minutely	1
13	Other engine problems resulting in seals operating outside design parameters, e.g. excessive rotor dynamics; higher operating temperatures	1
14	Poor bearing chamber design requiring seal to do harder job than intended allowing oil to exit chamber	1
15	High-pressure strong oil jets enable oil to go further than intended, hit wrong place - Forcing oil past seal.	1
16	Overfill - Oil forced out via vent/past seals	3
16a	Oil 'topping off'	4
17	Manufacturer defects	2
18	Other	
18a	Excessive eccentricity - Change of load around seal assembly if centre of seal and shaft do not align fully during assembly – Difficult to guarantee during assembly	4
18b	Stick lip - Polymer ages and becomes sticky around bearing and shaft causing lip of seal to stick, friction, wear, degradation, failure	2
18c	Vibration	2
18d	Cracking of the seal element on shaft. Therefore decrease pressure/small leak	1
18e	Excessive softening or hardening of compound - due temperature changes	1
18f	Corrosion of shaft- loss of material with lubricants	1
18g	Lubrication breakdown - Dry seal/excessive heat	1
18h	Fatigue of seal material. Above material limits	1
18i	Nicking, cutting & pitting - 1) in use 2) in installation	1
18j	Case leakage - Assembly between seal & casing leaks air & oil	1

18k	Air quality only tested at certification/oil levels only required to be within limits = under permissible leakage limits	1
-----	--	---

Several key themes were identified on why oil leakage past the compressor bearing seals occurs. These included design factors such as the use of seal types that are not an absolute design and will leak; reliance of the seals on pressure differentials; thermal and axial/radial changes in engine structures; leakage affected by engine speed and power and design parameters that do not account for all flight conditions. Other key engine operation factors include seal wear and degradation, on condition maintenance, installation, maintenance and in-use factors. The answers indicate this is a complex and very specialist area.

QUESTION 3: Does the phase of flight effect oil leakage rates?		
	ANSWER (11 of the 12 respondents answered this question in the following ways)	No.
1	Changing air/oil pressure differential with differing engine operating conditions	10
1a	Transients - Changing power settings changes internal engine pressures and balances	10
1b	Seal effectiveness/leakage is a function of engine momentary performance changes (temperature/speed, power, stage/application, phase of flight, ambient conditions) with seals reliant on correct air/oil pressure differentials either side of seals with fluctuating pressures and balances during different power and ambient conditions/transients decreasing efficiency and effectiveness of keeping oil in bearing chamber	9
1c	Momentary changing engine speed/power affects rates of differential pressure/balance over seals/reducing seal effectiveness with oil migrating over seal	6
1d	Acceleration/deceleration causes momentary varying pressure allowing oil into gas path - design may not account for this as transition deemed negligible	4
1e	Reverse pressures - wear/damage	3
1f	Changes of buffering air surrounding seals	2
1g	Seals take time to settle in after changes in power/pressures	2
1h	Ratio over seals must be correct to prevent leakage	1
1i	Changing shaft load changes pressure differentials over seals	1

1j	Oil pump pressure protects bearings on acceleration/deceleration – On acceleration oil pressure increases briefly in chamber (above air pressure) to protect bearings staying up briefly (above engine air pressure) on deceleration oil pressure remains higher in chamber briefly – reversal of flow	1
1k	FADEC - Changing power as engine chases airspeed	1
1l	Spools lose energy at differing rates with pressure gradients not same as during steady state	1
1m	Secondary air system designed for steady state conditions only	1
2	Mechanical (physical) variations in structures throughout entire engine operating range	7
2a	Thermal/axial-radial changes in engine structures - temperature and speed of engine causes metals to expand/contract with changing (air) gaps needing to be sealed to prevent oil crossing seal	4
2b	Shaft moves/varies in diameter with speed/temperature/performance, cooling & heating up effecting load conditions/clearance (air/gap) between shaft and seal	3
2c	Dimensions and tolerances most effective in cruise with seal effectiveness varying during transients	1
2d	Engine not operating at stable temperatures (start, early flight, top of descent, descent, approach) with seal clearances varying transiently	1
3	Low power settings-low internal pressures e.g. top of descent, descent, start, initial climb	6
4	Rain/anti-ice/turbulence - changes of airflow/moisture	2
5	Altitude: Pressure encountered by oil system varies with altitude	1
5a	Pressure balances correct during steady state allowing oil to flow correctly but may not be as required during transients allowing oil to flow in wrong direction	1
6	Attitude: Climb attitude not easily tested on test bed	1
7	Other	
7a	Highest level of performance during cruise	2
7b	Must take account of all physical changes in structures and pressures throughout entire engine operating range, yet regulations and designers only look at steady state conditions - not transients	1
7c	Oil tries to flow in all directions with enough air pressure required to prevent oil crossing seal	1

Several themes on why oil leakage past the compressor bearing seals occurs at differing phases of flight include the following.

- Changing pressure differentials and balances over the seals with differing transient engine power, application and ambient conditions affects seal efficiency and leakage rates;
- Mechanical variations (thermal, axial and radial) in structures over engine operating range changing gaps requiring to be sealed to prevent oil crossing seal;
- Low power settings - low internal pressures during start, spool up, top of descent, descent...

Again, the lower frequency responses are a combination of similar responses providing a comprehensive picture and a complex, specialist area of expertise.

QUESTION 4: Do some types of oil bearing seals leak more than others and why?		
	ANSWER (10 of the 12 respondents answered this question in the following ways)	No.
1	Carbon & Labyrinth seals	8
1a	Both leak for varying reasons - mechanical face seals rely more on physical contact, labyrinths seals rely more on pressure differential	5
1b	Seals will always have some leak/inherent in design as not absolute design	4
1c	All seals emit fluid	2
1d	Overfilling degrades seal performance	1
1e	Seal effectiveness mainly driven by design	1
1f	If seals and system operating as designed, oil should not leak but various factors degrade efficiency	1
1g	Condition of seal is important to prevent adverse effects of heat	1
1h	Oil sealing system is impressive, given harsh environment, with little possibility to improve designs	1
2	Carbon face (mechanical) seals	10
2a	Wear expected as contact seal with replacement interval required as wear continues	7

2b	Seal designed to have low level leakage rate as provides lubrication within seal	2
2c	More tolerant of pressure differentials than clearance seals	2
2d	Temperature critical with carbon deposits and hot spots from oil occurring - sticks, wear, degrades function	2
2e	Leakage occurs within and opposite direction of pressure drop	1
2f	Better as no gap and positive seal	1
2g	Can account better for rotor dynamics	1
2h	Leak less than labyrinths but do leak	1
2i	Leak more as rely on seal being seated correctly (minute gap allows leakage) and wear is greater issue	1
2j	Problematic if incorrectly installed or damaged	1
2k	Rely on physical contact pressure/not good in transients	1
2l	Period of readjustment when temperatures when speed/pressures change, causing short-term higher leakage	1
2m	Significant leakage during reverse pressures with seal face opening up	1
3	Labyrinth seals	7
3a	Should not wear but do, increasing over time	4
3b	Complex air system required with pressure drop over seal - Balance of pressures between front and rear of sump to prevent leaks	3
3c	Designed to leak small amount in direction of pressure drop due clearance including reverse pressures	2
3d	Oil can overcome positive pressure gradient	1
3e	Incorrectly installed/maintained, excessive wear, damage	1
3f	Used to leak more than carbon seals but improved technology has helped	1
3g	Sometimes used as back up to carbon seals along with buffered air	1

Both carbon and labyrinth seals leak for varying reasons with some leakage inevitable, as it is inherent in the design. Labyrinth seals rely more on pressure differentials with the clearance allowing leakage both with and against the pressure drop including reverse pressures over the seal. Carbon seals are designed to have low leakage rates as lubrication is required between the faces and rely more on physical contact more subject to wear and high temperatures.

Leakage also occurs with and against the pressure drop. Again the various responses provide a comprehensive picture in a complex area.

QUESTION 5: How is lower level leakage of oil from the compressor-bearing chamber at various phases of flight perceived with regard to regulatory compliance?		
	ANSWER (8 of the 12 respondents answered this question in the following ways)	No.
1	Regulations and standards	
1a	No published limits, recognized methods of measurement or regulations addressing oil contamination exist	3
1b	No action required if oil usage within useable maintenance manual limits	2
1c	Unaware if oil leakage is required to be measured, with suggestion to measure leakage using equipment rather than human nose	1
1d	No requirement to measure transients during certification	1
1e	Low level leakage is normal part of design and use of engine bearing/seal systems and fails to meet published design requirements	1
1f	If have leakage, then not compliant but difficult to quantify	1
1g	Should not be contaminants in cabin air that exceed established limits regardless of flight conditions	1
2	Enforcement	
2a	Regulators very reluctant to enforce this area/standards for contamination ignored	2
2b	Cost of maintenance/cost minimisation override regulatory enforcement	1
2c	Industry does not admit there is an issue	1
3	Other	
3a	Measurement of leakage rates not adequately addressed	2
3b	Defect continues to be investigated until pilot reports stop	1
3c	No need to quantify leakage until crew/passenger reports received with investigation undertaken only after leakage has occurred	1
3d	Mitigating leak into cabin should be much higher priority, but not seen as a problem	1

Responses provided indicate there are no regulations, limits or measurement methods for air contamination by oil. Differing views indicate action is only required if leakage is above useable limits and alternatively that low level leakage is expected as part of the system design and fails to meet published design requirements. Regulatory enforcement is regarded as a low priority with standards available ignored.

QUESTION 6: What can be done to address oil leakage from the compressor bearing chamber?

	ANSWER (10 of the 12 respondents answered this question in the following ways)	No.
	Maintenance	
1a	Develop, implement and enforce rules for preventative maintenance to minimize incidents	5
1b	Oil consumption trends do not focus on oil in bleed air but should	2
1c	Change seals more frequently	1
1d	Ensure proper maintenance	1
2	Regulation and compliance	
2a	Find new way to get air into cabin - Eliminate bleed air - Use electric supply	7
2b	Measurement should be undertaken in real-time, not after events or reliance on human nose	7
2c	Mitigating oil leaks into cabin given much higher priority	2
2d	Use filtration on bleed air system	2
2e	Improve design and quality of parts/seals	2
2f	Requirement to avoid exposure	2
2g	Improve design of bleed air and oil system	1
2h	Seal system design has run its course, find alternative ways to address	1
2i	Air quality standard required (evaluation of air quality) in addition to present entire focus on engine pressure levels	1
2j	Define level of emission through seal	1
2k	No blame rules to encourage reporting	1
2l	Use additional seal systems to contain oil	1

Responses again provided a comprehensive picture rather than varying responses. Preventative maintenance, real time measurement, electric air supply rather than cabin bleed air and mitigating oil leaks into the cabin to be given a higher priority, are a few of the suggested ways forward to address compressor oil leakage.

QUESTION 7: What is considered oil leakage?		
	ANSWER (10 of the 12 respondents answered this question in the following ways)	No.
1	Any condition where oil leaves the areas in which it is supposed to operate - Or resides in a greater amount or rate than by design - Vapour, drip, seep, leak	5
1a	Human nose identification of oil	3
1b	Loss of fluid over seal	2
1c	Leakage depends on application and perceived hazard in particular industry	1
2	Allowable oil consumption limits & pressure differentials	5
2a	Leakage above allowable oil consumption limit - Low oil contents	3
2b	Engine consumes oil as normal part of system function/expelled via breather system	2
2c	Pressure differences & quantity of oil consumption considered only, but not emissions	1
2d	Focus entirely on prevention of in-flight shut-down	1
3	Emissions	2
3a	Oil fumes identified well below permissible leakage levels - too low to be identified during inspection	1
3b	Emissions from oil ignored	1

Oil leakage is seen in two key differing ways. Any oil that leaves the intended area, resides in areas in a greater amounts than intended or loss over seals is leakage. Alternatively, only loss above permitted oil consumption levels or inadequate system pressure differentials is regarded as leakage, but not lower-level oil emissions.

QUESTION 8: Are all oil leakage events documented?		
	ANSWER (11 of the 12 respondents answered this question in the following ways)	No.
1	No	9
1a	Under-reporting due fear of jeopardising employment - lack of education/awareness of exposure/reports not passed on by airline	5
1b	Maintenance report/action depends on crews reporting cabin odour via technical log	4
1c	Record keeping and reporting varies amongst airlines	3
1d	Lack of maintenance records indicates improper procedures/maintenance	1
1e	No requirement to record oil in bleed air trends	1
1f	Investigations not undertaken to level required and regulatory standards not appropriately followed	1
1g	Perceived as industrial issue with regulatory standards not followed adequately	1
1h	Detection depends on human nose/company policy	1
1i	Seals may not be inspected during specific maintenance	1
1j	Specific tests required for certification will be recorded/other tests not mandatory may not get passed on	1
1k	Oil topping off is a normal maintenance procedure	1
2	Yes	2
2a	Reports required by maintenance/training manuals	1
2b	Leakage identified in engine pressure sensors as per maintenance manual	1
2c	Events causing impairment, diversions, flight curtailment may be recorded under flight delay reporting	1
2d	If seals removed as part of maintenance schedule, then damage reported	1
2e	Regulators only recently have required reporting of leaks	1

Question 8 responses found the majority believe that not all leakage events are reported for a variety of reasons including under-reporting, varying record keeping and maintenance dependent on crews identifying odours via the technical log. A small minority focussed on the requirement to report, mandatory

maintenance procedures being recorded and higher-level events only. This answer like all others, identified a comprehensive picture, differing opinions, and also opinions based on area of expertise alone.

4.2 Aviation Regulators

4.2.1 General

Both EASA and the FAA were selected to participate in the interview process. EASA is the sole authority within the EU member states entitled to undertake type and airworthiness certification, while the FAA was chosen as a key national agency undertaking these functions.

Other national agencies within Europe advised that they either relied upon or provided limited services supporting EASA. Outside Europe, many countries largely utilise the FAA or EASA type certification by way of bilateral agreements or may conduct their own certification in parallel to the FAA or EASA process. Differences with key international agencies were reported to be minimal or non-existent.

4.2.2 Interview Objectives

The overall aim of the interviews was to determine the real world process by which the regulators certify and ensure airworthiness compliance for the purity of the bleed air supply to the aircraft cabin.

The interviews consisted of written questions with telephone or email follow up as required.

4.2.3 Limitations

By asking the questions in a qualitative manner, the responses provided were somewhat limited by the time allocated to responding, and answers that highlighted parts of the actual standard, rather than their interpretation.

4.2.4 Analysis of results

QUESTION 1: What is the certification process that an engine and APU manufacturer must follow to demonstrate compliance with the requirements of the quality of bleed air utilised for the aircraft cabin?

FAA

Type certificate applicant must show compliance with all applicable requirements, provide the FAA the means by which compliance has been shown and a statement regarding all requirements having being met (14 CFR 21, §21.20).

The applicant submits and the FAA finds the type design, test reports and computations necessary to show the product to be certified meets applicable airworthiness, aircraft noise, fuel venting and exhaust emission requirements. No feature or characteristic makes the aircraft unsafe (14 CFRS 21.21; 33 §33.1; 34).

EASA

Type certificate applicant must show compliance with certification standards CS-E and CS-APU, however there is no requirement to follow a specific process to demonstrate the compliance.

CS paragraphs and the related AMC provide the manufacturers guidance to demonstrate compliance with the CAQ requirements.

Interactive process between manufacturer & EASA engineers with the manufacturer providing a description of compliance and tests undertaken with subsequent agreement on process.

While the applicant must show compliance with the regulations or standards and the means by which compliance is met, there is no specific process to follow to demonstrate this, however guidance is provided. The regulator interactively will review the data submitted to enable agreement that compliance is met.

Question 2: What are the relevant certification standards, acceptable means of compliance (AMC) used to demonstrate bleed air compliance?

FAA & EASA

- Regulation CFR14 33 §33.75 - Certification Specifications CS-E 510
- Engine certification applicant must undertake a safety analysis of the engine to assess likely consequences of all failures that can reasonably be expected to occur, including compressor bleed systems (§ 33.75; CS-E 510) demonstrating:
- Hazardous engine effects including “Concentration of toxic products in the

engine bleed air intended for the cabin sufficient to incapacitate crew or passengers” are predicted to occur not greater than – ‘extremely remote.” (FAA, 2007; EASA, 2015)

- Absolute proof of hazardous effect probabilities is not possible with compliance shown by reliance on engineering judgement, previous experience, sound design and test philosophies (§ 33.75/CS-E & AMC E 510) and prescribed integrity specifications (CS-E 515).

Acceptable Means of Compliance: (FAA) AC 33.75-1 - (EASA) AMC E 510

1. Toxic products: products that act as or have the effect of a poison when humans are exposed to them.
2. Toxic products are considered a ‘hazardous’ engine effect if the toxic concentration levels from abnormal engine operation are sufficient to incapacitate the crew or passengers. Examples include a) the flow of toxic products are so quick-acting as to be impossible to stop before incapacitation occurred; or (b) no effective means to stop the flow of incapacitating toxic products to the crew compartment or passenger cabin; or (c) The toxic products would be undetectable before incapacitation.
3. Toxic products could result from degradation of oil that could leak into the compressor airflow.
4. Delivery rates and concentrations of toxic products in the engine bleed air for the cabin to be listed in the installation instructions.

Applicants may show compliance with CS-E & § 33.75(g)(2)(ii) through analysing the relative concentration of toxic products in engine bleed air.

FAA

- Hazardous effect - 10^{-7} to 10^{-9} per engine flight hour / (10^{-8}).
- Oil leakage past engine seals is a failure condition if it caused a fire or is in sufficient quantity (in given flight) to incapacitate crew or passengers.

EASA

- Hazardous effect - 10^{-7} to 10^{-8} /efh
- Major effects to occur not greater than ‘remote’ ($< 10^{-5}$ /efh).
- CS-E 690: Contamination tests of bleed air for cabin pressurisation or ventilation(1) Tests to determine the purity of the air supply must be made and (2) an analysis of defects which could affect the purity of the bleed air must be prepared and where necessary the defects must be simulated and tests, as agreed by the Agency.
- CS-APU 210 with specific reference to CS-APU 210 (g)(2)(ii) - (Very similar to CS E and AMC).
- CS-APU 320 - Provide characteristics of APU bleed air contaminants.

The safety analysis process and published acceptable methods of compliance for both regulators is essentially identical. Hazardous engine effects, including concentrations of toxic products resulting from degradation of oil leaking into the compressor air flow, sufficient to incapacitate crew or passengers must be predicted to be extremely remote. While both require analysis of concentrations of toxic products in the bleed air, the EASA specifications are more specific with engine bleed air purity tests and an analysis of possible defects effecting purity also required.

<p>QUESTION 3: Which substances are reviewed and what limits are applied demonstrating compliance?</p>
<p>FAA</p> <p>There are no specific regulatory limits for toxic substances in bleed air except as specified in §33.75 - Concentration of toxic products in the engine bleed air intended for the cabin sufficient to incapacitate crew or passengers.</p>
<p>EASA</p> <p>SAE ARP 4418A “Procedure for Sampling and Measurement of Engine and APU Generated Contaminants in Bleed Air Supplies from Aircraft Engines” is utilised as criteria when checking compliance with the CAQ requirements.</p>

While there is a requirement to prevent incapacitation from toxic bleed air substances, there are no specified regulatory limits. EASA however referred to SAE standard limits as a means to demonstrate compliance.

<p>QUESTION 4: Was there any difference in previous years with what was deemed acceptable to demonstrate compliance?</p>
<p>FAA</p> <p>Prior to 2007 §33.75 the wording relating to toxic products in the engine bleed air did not exist</p>
<p>EASA</p> <p>n/a</p>

The reference to toxic products did not exist under the FAA safety analysis regulations for aircraft certified before 2007. While EASA did not respond to this

question, the initial CS E section in 2003 is effectively the same as the present version. The last version of the JARs published in 2001 referred to 'unacceptable concentrations' of toxic products generated in air supplied in the guidance material.

QUESTION 5: If applicable, what defects that could affect the purity of the bleed air might be considered and what tests may be undertaken?

FAA

AC 33.75-1 - Toxic products could result from the degradation of abradable materials in the compressor when rubbed by rotating blades or from the degradation of oil that could leak into the compressor air flow.

The guidance does not specifically refer to tests for toxic substances in bleed air.

EASA

AMC: E 510 & CS-APU 210 - Degradation of oil and abradable materials into the compressor air flow

CS E 690 - Bleed air purity tests and analysis and possible simulation of defects

The FAA referred to the Advisory Circular guidance material listing oil leakage and degradation of abradable materials into the compressor air flow, without supplying specific defects enabling this to occur. While tests for toxic substances are not defined, EASA standards require analysis and possible simulation of defects as part of the contamination cabin bleed air tests.

QUESTION 6: What is the cabin air quality certification process and acceptable means of compliance at the airframe level and which substances and limits are included?

FAA: 25.831

Passengers and crew must have 'sufficient uncontaminated' air to allow reasonable comfort during normal operating conditions and after a 'probable' failure of any system that would adversely affect the cockpit or cabin ventilation air.

There is no requirement that the air be 'pristine' free of any contaminants such as dust or gases.

Limits are provided for minimum ventilation airflow, CO, CO₂ comparing favourably with other transportation systems.

Previous compliance on earlier programs was limited to measurements of temperature, airflow, CO, CO₂ and O₃. Recent airplane certification programs require

manufacturers to address the recommendations from the NRC Report on the Cabin Airliner Environment (2001), which ranked carbon monoxide, hydraulic fluids or engine oils or similar contaminants or the breakdown of these contaminants during normal flight as medium priority.

Some manufacturers show compliance to additional contaminants as recommended by: ASHRAE Standard 161P and European Union (E.U.) AECMA-STAN standard for acceptable air quality. The latest programs demonstrate compliance via design practices, analysis, component level tests, airplane system level tests and real-time and sampling measurements.

Aircraft manufacturers use company design specifications based upon industry standards, recognised medical standards and their own historical expertise including: DO-160 Environmental Conditions and Test Procedures for Airborne Equipment; SAE guidelines - ARP85 Air Conditioning Systems for Subsonic Airplanes; AS5379 Valves, Safety, Cabin Air; ARP1270 Aircraft Cabin Pressurization Criteria; ARP1533 Procedure for the Analysis and Evaluation of Gaseous Emissions from Aircraft Engines; ASHRAE Standard 62-1989 Ventilation for Acceptable Indoor Air Quality; ASHRAE Guideline 28-2012, Air Quality within Commercial Aircraft; U.S. Department of Defense Publications.

EASA: CS 25.831 / AMC

Each crew compartment must have enough fresh air (minimum level listed) enabling crewmembers to perform duties without discomfort or fatigue.

Compartments must be free of harmful or hazardous concentrations of gasses or vapours. Levels provided for CO, CO₂ and O₃.

The airframe requirements are very similar requiring enough fresh air to avoid discomfort and fatigue and provide reasonable comfort, a minimum airflow and are interpreted to consider CO, CO₂ and O₃ only. However, the FAA has required recent certification programs to address the NRCs CAQ recommendations including oils and the degradation products into the cabin air. A range of additional standards and guidelines are listed as optionally utilised by manufacturers demonstrating compliance.

Question 7: What are the general sources of data used to indicate that the power units and aircraft meet the required standards?

FAA

Engine level - Applicants submit a report to the FAA demonstrating compliance with §33.75 - toxic products sufficient to incapacitate crew/passengers not in excess of extremely remote.

Airframe level

General sources of information as listed in Q6 and FAA Report to NRC:

- Thermal stress. Fundamentals of Aerospace Medicine (3rd ed.);
- ASHRAE Research Project 957-RP, February 1999;
- Environmental Survey on Aircraft and Ground-Based Commercial Transportation Vehicles, Harvard School of Public Health, 1997;
- High Altitude Medicine and Physiology (2nd ed.) 1995;
- NIOSH Health Hazard Evaluation Report, Alaska Airlines. 1993;
- U.S. Department of Health and Human Services, Public Health Service, Centers for Disease Control.

EASA

Interactive process between EASA and manufacturer

The source of data to show compliance is up to the manufacturers. The data provided is interpreted as evidence that incapacitation will not occur above the given rate and a range of sources at the airframe level are utilised.

5 DISCUSSION

5.1 Introduction

The aim of this research was to assess whether there is any gap between the aircraft certification requirements for the provision of clean air in crew and passenger compartments using the bleed air system and the theoretical and practical implementation of the requirements. The research results obtained and existing literature has clearly identified differing understanding of bleed air supply contamination between seals and aero engine experts compared to the wider aviation industry.

5.2 Overview of Research Methods

A thorough literature review was undertaken to gain an understanding of the relevant certification requirements along with the general industry and specialist understanding of oil leakage to answer two of the research questions.

Gas turbine engineering professionals and seal experts were interviewed using open-ended questions regarding their understanding of oil leakage past compressor oil bearing seals. EASA and the FAA were interviewed using open-ended questions to provide their interpretation of the certification process related to the clean air requirements. The qualitative format in a highly complex area was influenced by time limitations in responding in a highly complex area and individual expertise. Answers were generally part of a broader category, yet the author chose to use narrow and low response rate sub categorisation, to provide a comprehensive picture and not lose detail in this specialist field.

5.3 Research Objectives Discussion

5.3.1 Standards and Guidance Material

There are various certification requirements and associated AMC published (s.2.2) for the provision of clean air in the crew and passenger compartments, that ought to be acceptable in demonstrating compliance. However, there are a number of deficiencies in the descriptive terminology and the presentation of the requirements between standards and guidance material. This could enable the

compliance requirements and AMC to be interpreted in a number of ways or with lesser priority. The engine safety analysis lists the toxic products in the bleed air sufficient to cause incapacitation in the standard. Oil leakage into the airflow and degradation of crew performance are included in the non-mandatory guidance material. This may allow a lesser priority to be placed on leakage causing impairment.

Prior to 2007 the FAR engine safety analysis (§33.75) did not reference toxic products in the bleed air. The past and presently used phraseology, 'concentration of toxic products sufficient to cause incapacitation or degrade crew performance or unacceptable concentrations of toxic products', do not provide specific guidance to acceptable levels. Warning systems required for 'unsafe system operating conditions' may allow room for interpretation on whether detection systems are required for oil leakage. There may also be room for interpretation regarding the ventilation standard 25.831. The terms 'enough clean air' or 'sufficient amount of uncontaminated air' may allow the focus to be on the airflow rates listed rather than fresh air preventing undue discomfort. The requirement for air to be free of harmful and hazardous gases and vapours, could be interpreted to refer to all substances or CO, CO₂ and O₃ only.

EASA CS bleed air purity tests require analysis and possible tests of defects affecting the purity of the air, however, no further guidance is provided. The safety analysis for both the FAR and CS, must include toxic products in the compressor bleed air, yet no guidance is provided. It is left to the manufacturer to demonstrate compliance.

There are however, some broader requirements. Systems must be designed to perform their intended functions under foreseeable operating conditions. Unsafe conditions refer to events occurring more frequently than intended causing impaired crew efficiency, discomfort or injuries.

5.3.2 Theoretical Understanding

There is a clear discrepancy in the understanding of oil contamination of the bleed air supplied to the cabin. The general understanding within and outside

the aviation industry (s.2.1) varies markedly to seal and aero engine experts (s.2.3), specifically those involved in the bearing chamber/engine design and maintenance areas.

The general understanding primarily supports rare oil leakage due to failed bearing seals. Further damaged or worn seals, seals not working properly under abnormal conditions or overfilled sumps are commonly referenced. There is a less well-publicised recognition that oil leakage may occur as a design factor. Oil seals are required to seal across the entire engine operating range, but are less efficient during transient engine manoeuvres. Oil substances are repeatedly being identified at background levels in monitoring studies. Some even report somewhat continuous tiny amounts of oil crossing the seal. Studies undertaken generally report exposures to oil fumes as safe, with low-level exposures regarded as normal and safe, associated with discomfort only.

The literature supporting the engine and sealing experts understanding of oil leakage is not readily accessible or referenced when the topic of oil leakage is raised. However seal leakage at lower levels is widely recognised. Pressurised compressor air is used to seal the bearing compartment, but is responsive to variations in engine operating conditions. The commonly used bearing compartment seals, both allow lower-level oil leakage across the seal. Labyrinth seals rely on a clearance and do not in isolation prevent leakage. Mechanical carbon face seals require oil to lubricate the faces with minimisation of leakage across the faces. Various operational factors allow increased oil leakage over both seals, including wear, changes in clearances, seals not at operational temperature or pressures and during transients. Positive pressure gradients over the seal do not fully prevent leakage. Reverse pressures, which do occur, will allow leakage in the opposite direction.

While selected aviation standards related to clean air do exist, several factors stand out (as outlined below) as why some experts may regard lower-level oil leakage as acceptable (s.2.3).

- Leakage over seals is a normal part of permissible oil consumption limits;

- Belief that permissible leakage is driven by consumer perceptions rather than regulatory emission limits;
- Sealing the bearing chamber at near ambient pressures is difficult;
- Oil leakage is viewed differently - high level mist or low level emission;
- High awareness of seal technological limitations and concerns about oil leakage out of the bearing chamber, yet no real moves towards advanced sealing, particularly for current aircraft.

The literature indicates that the different groups are not suitably communicating with each other to fully understand the risks.

5.3.3 Feasibility of Implementation of Standards

Despite, the small sample size, the engineering and seal experts were highly experienced (s.4.1.2). Eleven out of the twelve experts recognised low-level oil leakage or emissions over the oil seals are a part of the system function of utilising pressurised oil bearing seals. A wide variety of factors, including those set out below, were identified that allow oil to enter the compressor air and the bleed air system (s.4.1.5, Q 1-4).

- Changes in pressures and balances during different engine operating and ambient conditions/transient performance changes reducing seal efficiency;
- Thermal, axial and radial changes in engine structures cause changes in gaps needing to be sealed over whole engine operating range;
- Low internal pressures at various phases of engine operation;
- Standards and designs modelled on steady state conditions, not transients;
- Seals are not an absolute design, enabling leakage;
- Seal wear/component degradation.

Based upon the responses provided by the engineering and seal experts and regulators, there appears to be a discrepancy between the design standards and their implementation with the use of the bleed air system (s.2.2; s.4.1.5; s.4.2.4).

Table 1 (EASA) and Appendix B (EASA; FAA) show the key requirements and non-mandatory compliance material, (including differences) for the airframe and engine and APU where applicable.

The standards require 'major' engine/APU effects to not be greater than 'remote' (10^{-5} – 10^{-7} /efh). 'Major' effects compliance guidance includes oil leakage into the compressor airflow sufficient to degrade crew performance. The regulators, however (s4.2.4, Q2-3) place the emphasis on the regulation/standard involving 'hazardous' effects including toxic products sufficient to cause incapacitation, with no mention of 'major' effects (FAA) and effectively no reference by EASA. Reliance on the regulation/standard was clear with the compliance guidance effectively ignored.

The FAA airframe standards do not allow failure conditions, reducing the crew's ability to cope with adverse operating conditions to be more than 'improbable'. EASA airframe standards require 'major' failure conditions to be no more than 'remote'. Major failure conditions under the EASA AMC include impaired crew efficiency, flight crew physical discomfort or physical distress of other occupants occurring no more than remotely (1×10^{-5} /fh). Remote (EASA) failure conditions may occur several times during the total life of a number of aeroplanes of type, but are unlikely to occur to each aeroplane. The FAA terminology varies (Appendix B), but the intent is similar.

The regulator responses regarding compliance at the airframe level took part of the requirements into account only. CS and FAR 25.831 requiring a 'sufficient amount of uncontaminated' or 'fresh air' were highlighted, while general airworthiness requirements including 'major' effects and impairment (25.1309 and AMC) were ignored (s.4.2.4 Q6). This indicates that in terms of CAQ and oil contamination, the airframe certification requirements are not being adequately applied.

Importantly, exposure to lubricants is associated with adverse effects and is expected to occur more than remotely or improbably, based on the design, hazard recognition and frequency reported (s.2.1.2; s.2.1.6; s.2.3; s.4.1.5 Q1-4,8).

<p>Legend: <u>Bold underlined typeface</u> = Part of certification standard Plain typeface = Part of AMC Italics = What is most commonly being seen in practice/AMC</p>	
EASA - Airframe - CS 25.1309 & AMC Airworthiness	EASA - Engine/APU CS-E 510 & CS-APU 210 Safety analysis
<p><u>HAZARDOUS - Extremely remote</u></p> <p>Will not occur to each aeroplane but may occur a few times during total life of all aeroplanes of type.</p> <p>$1 \times 10^{-7} - > 1 \times 10^{-9}$ /flight hour.</p> <p>Physical distress - pilots.</p>	<p><u>HAZARDOUS - Extremely remote</u></p> <p><u>< 10^{-7} /engine/APU flight hour</u></p> <p><u>Toxic products in bleed air sufficient to incapacitate crew/passengers.</u></p> <p><i>Oil leaking into compressor airflow = toxic product.</i></p>
<p><u>MAJOR - Remote</u></p> <p>Unlikely to occur to each aeroplane but may occur several times during total life of a number of aircraft of type.</p> <p>$\leq 1 \times 10^{-5} - > 1 \times 10^{-7}$ /flight hour.</p> <p><i>Impaired crew efficiency, discomfort to pilots, physical distress, injuries to other occupants.</i></p>	<p><u>MAJOR - Remote</u></p> <p><u>< 10^{-5} /engine/APU flight hour</u></p> <p><i>Toxic products in bleed air for cabin sufficient to degrade crew performance.</i></p>
<p>MINOR - Probable</p> <p>$> 1 \times 10^{-5}$ per flight hour.</p> <p><i>Occurs 1+ times to each aeroplane during total life.</i></p> <p>Pilot actions well within capabilities/physical discomfort to other occupants</p>	

Table 1: EASA Airframe & Engine/APU CS & AMC

Based on engineering judgment provided in this thesis, ‘major’ engine effects involving oil leakage are occurring more than 1×10^{-5} /engine/APU flight hour

(s.2.3; s.4.1.5). As the oils are accepted in a variety of ways as being associated with adverse effects (s.2.1.6, p15), impaired crew efficiency or degraded crew performance can occur with exposures.

The frequency meets the definition of 'probable'. As shown in Table 1 and Appendix B, probable failure conditions may not be greater than minor and may not have adverse effects on occupants (FAA) or flight crew (EASA). Figure 2 indicates that EASA airframe probable failures should not be more than $1 \times 10^{-3}/\text{fh}$, with those more frequent again stated to have no effect on flight crew or inconvenience only to others and no safety effect. Exposure to oils via the bleed air system does not meet this. Major effects are expected which must be improbable or remote.

It may be that those responsible for certification and continuing airworthiness are primarily relying on engineering judgment and analysis to determine the probability of failure conditions and engine effects, without adequately reviewing other factors. In-operation occurrences, under-reporting, hazardous substances, design enabling low-level exposures, and adverse effects on occupants are examples of other factors to be considered.

The ventilation standard 25.831 was interpreted (s.4.2.4 Q6) to include only a sufficient amount of uncontaminated air, enough fresh air to prevent discomfort and fatigue, specified ventilation rates, CO, CO₂ and O₃. More recent certification programs have included reference to a number of industry air quality studies and guidelines to determine what is deemed acceptable (s.4.2.4 Q6-7). However, not all are relevant and some such as AECMA-STAN, no longer exist.

The regulatory emphasis is focusing on the 'hazardous' engine effects of toxic products sufficient to incapacitate, with little or no recognition of 'major' effects causing impairment. Impairment and discomfort related to the airframe are either being ignored or limited to selected flow rates, limited substances and industry studies.

Alternatively as lower level leakage occurs as an expected function of various phases of engine operation, it could be suggested that the oil system is working within its intended function. Oil leakage over the seals may be a normal as distinct from a failure condition.

Despite accepted oil leakage in normal operations, there were various contrasting views on acceptability of the leaking oil including: (s.4.1.5 Q5) No action required if the leakage is below the permissible leakage levels and within engine pressure limits; transients not measured; no oil published limits or standards exist; contaminants must be within established limits and normal low level leakage fails to meet the standards. Other key issues include that low-level emissions are ignored; under-reporting is occurring and low priority is given to preventative maintenance and regulatory enforcement.

The non specified or limited substances referenced under the engine/APU safety analysis, and ventilation requirements help explain the difficulty in determining the acceptability of oil contamination of the air supply (s.4.2.4 Q3,5,6-7). The FAA interpretation of the engine analysis requirements was limited to toxic substances sufficient to incapacitate. EASA referenced an industry standard (SAE4418) that list limits for a few substances and relates to steady-state engine operation only. The previously used compliance specification (MIL-E-5007) did not allow any oil leakage into the bleed air (s.2.2.2).

The lack of detection systems and warning indicators to identify oil fumes in flight fails to meet the regulatory requirement, (25.1309c) and causes compliance problems. This also poses difficulties in post flight maintenance rectification (s.4.1.5 Q5-8).

Leakage of oil into the bleed air meets the definition of an 'unsafe condition', (s.2.2.1.5) and an unsafe (air supply) system operating condition.

Type certificate applicants submit a report to the regulator showing how compliance has been met. However, there is no requirement to follow a specified procedure (s.4.2.4 Q1-3,5-7). In a similar manner, bleed air analysis

for certification appears to also be non-specific. The FAA does not refer to specific tests that are to be part of the safety analysis, yet engines are required to provide bleed air without adverse effects on the engine. EASA refers to bleed air purity tests but does not outline what the tests are or under what conditions they need to be undertaken.

In addition to the non-specific requirements related bleed air contaminated by oil and oil sealing of the bearing chamber, this is a highly specialist area. Different experts appear to have their part of the picture only and interpret acceptability in light of their experience. This becomes problematic in such a safety critical area.

A number of ways to improve the situation were presented (s.4.1.5 Q6) including: improved preventative maintenance; better seal, oil sealing system and bleed air designs; increased seal replacement frequency; elimination of bleed air and use of an electric air supply; in flight real-time monitoring; bleed air filtration; define emission through seals; avoidance of oil fume exposure in the cabin; better regulatory and air quality standards and improved compliance and reporting.

5.3.4 Reluctance to Change

Despite lower-level oil leakage recognition within the seals and aero engines design community, the aviation industry has failed to address the situation. A number of factors were identified in the research allowing the problem to remain unaddressed. These include data not collected and reviewed adequately; no manufacturer will make significant changes without regulatory requirement given assumed high cost; apparent disincentive to change; regulations, standards and intent of AMC are inappropriately being deemed to be acceptable and met and inadequate understanding of low-level exposure to hazards. It seems likely that the industry expects the regulator to take the leading role to enforce change.

6 CONCLUSIONS AND RECOMMENDATIONS

6.1 Conclusions

In current transport aircraft, exposures to lower-level oil fumes containing hazardous and harmful substances, was found to be occurring in normal flight via the aircraft bleed air supply. Resulting adverse effects are creating a risk to flight safety.

The research undertaken has found that there is a gap between the aircraft certification requirements for the provision of clean air in crew and passenger compartments using the bleed air system and the theoretical and practical implementation of the requirements. Oil bearing seals are not an absolute design and will allow low-level oil leakage over the seals into the compressor and bleed air supply as a normal function of the engine cycle. Lower-level oil leakage is not exclusive to failure or mechanical abnormalities.

6.1.1 Regulations & Standards

(s.5.3.1; s.5.3.3)

Based on a review of the applicable regulations, standards and guidance material and interviews with highly experienced aero and seal experts and regulators, the required bleed air quality is not being met. The standards and compliance material are not specific enough to ensure suitable bleed air quality. The focus is placed on the standard and prevention of incapacitation, with compliance guidance material and impairment almost ignored. The clean air requirements are open to interpretation and are not taking into account the in-operation environment, including hazardous substances and adverse effects, low-level normal leakage, frequency, under-reporting and lack of detection systems.

6.1.2 Design

(s.5.3.2; s.5.3.3)

Low-level oil leakage over the bearing seals into the bleed air, at various phases of engine operation is an expected normal condition, according to the seals and aero engine experts. While it appears that enough is being undertaken to meet the certification requirements, careful review of the literature and research undertaken with engineering and seal experts, shows the regulations are not being met. As demonstrated in the literature and supported by the engineer and seal experts interviews, the airframe failure conditions and engine/APU safety analysis requirements are not being met. Oil leakage past the seals, associated with impaired or degraded performance, occurs more frequently than the 'major' EASA, and FAA regulatory and compliance criteria allow (Table 1; Appendix B). Oil leakage, capable to cause degraded performance and efficiency is occurring on a greater than 'remote' or 'improbable' basis. Oil leakage in normal operations is probable or above (Figure 1, Figure 2, Table 1, Appendix B) and meets the definition of an unsafe condition (s.2.2.1.5).

6.1.3 Compliance

(s.5.3.1; s.5.3.3)

Although inadequate, compliance is undertaken at certification. However, no detection systems are available in-flight to monitor the quality of the air, including low-level leakage in normal operations. The ventilation requirements are not specific enough to ensure occupants will remain free of adverse effects.

6.1.4 Preventative Control Measures

(s.5.3.3)

Low-level and transient oil emissions are not adequately taken into account when considering acceptable leakage levels. Designs are based on steady state conditions, although oil leakage will be minimally occurring during certain engine power conditions and transients. There are no contaminated bleed air

detection or filtration systems to identify and protect occupants from oil fumes. Rigorous controls are lacking including: improved designs, better maintenance and procedures and suitable air quality emission definitions.

6.1.5 Retrospectively

(s.5.3.1)

Previous engine certification requirements either did not include toxic effects or were not specific enough to prevent oil leakage into the air supply.

6.1.6 Expertise and Communication

(s.5.3.3)

Oil contamination of the air supply is a highly specialist area, with inadequate communication between all relevant parties to ensure compliance and airworthiness.

6.2 Recommendations and Future research

Based upon the literature and the research, it has been demonstrated in terms of clean cabin air supply that the standards and compliance guidance are inadequate and not being met. This is a highly specialist area with various actions suggested to be undertaken to meet the requirements for the supply of clean cabin air. These include the establishment of a specialist task group, including the regulators, to review the following.

1. The adequacy of the air quality related standards and compliance guidelines, in light of the real-world understanding of oil leakage into the bleed air supply.
2. Solutions and preventative measures that could be introduced to prevent exposure to engine lubricants in normal operations.
3. The reasons why the industry is reluctant to address the prevention of in-flight exposure to lubricants.
4. Further recommendations:

- Oil contamination of the bleed air supply should not be linked exclusively to rare failure conditions or maintenance irregularities,
- The frequency should be seen in terms of design factors rather than the rate of reporting,
- Actions should be undertaken to prevent oil leakage into the aircraft air supply in normal operations,
- Aircraft certified prior to the current standards should be retrospectively re-certified for bleed air quality,
- Future aircraft air supply systems should use bleed free designs,
- Far greater priority should be placed on clean air regulatory compliance including low-level oil emissions in normal flight,
- In flight oil fume detection systems and flight-deck warning should be implemented on all future aircraft.

6.3 Research Objectives and Accomplishments

The following research objectives were all met (s.1.2.2).

1. To evaluate the aircraft certification requirements for the provision of clean air in crew and passenger compartments and the processes in ensuring their compliance.
2. To assess the theoretical documented understanding of the potential conditions in an aircraft bleed air system that may lead to contamination of air supplied into the crew and passenger compartments.
3. To assess the feasibility of the implementation of the aircraft certification requirements for the provision of clean air in crew and passenger compartments in a real world situation, specifically in the context of the potential contamination caused by various conditions in the aircraft bleed air system.

4. To provide conclusions and recommendations for the aviation industry and authorities with regard to the provision of clean air in crew and passenger compartments using the aircraft bleed air system.

The research undertaken has demonstrated that there is a gap between the effectiveness of the aircraft bleed air supply regulatory and compliance process and the supply of clean air to the crew and passenger compartments. The regulator process, although appearing to be met, is not sufficient to ensure that the breathing air will not lead to impaired crew efficiency and degraded crew performance and adverse effects on other occupants.

REFERENCES

AAIB (2004) *EW/C2000/11/4. Aircraft Accident Report No. 1/2004.BAe 146-200, G-JEAK*. Aldershot: AAIB.

AAIB (2006) *Report No. u1884. Investigation Report Concerning The Serious Incident To Aircraft AVRO 146-RJ 100, HB-IXN*. Berne: AAIB, Switzerland.

AAIB (2009) *EW/C2006/10/08. AAIB Bulletin: 6/2009 G-BYAO*. Aldershot: AAIB.

AAIB (2013) *EW/G2012/10/12. AAIB Bulletin: 5/2013 D-AIRX*. Aldershot: AAIB.

Abou-Donia, M. B., Abou-Donia, M. M. and ElMasry, E. et al. (2013) 'Autoantibodies To Nervous System-Specific Proteins Are Elevated In Sera Of Flight Crew Members: Biomarkers For Nervous System Injury', *J Toxicol Environ Health A*, 76(6), pp. 363–380.

ACGIH (2015) *TLVs and BEIs - Threshold Limit Values For Chemical Substances And Physical Agents*. Cincinnati: ACGIH.

AGARD (1978) 'Seal Technology in Gas Turbine Engines', in *AGARD Conference Proceedings No. 237- Seal Technology In Gas Turbine Engines*. London: NATO-AGARD.

ASHRAE (2013) *Standard 161-2013. Air Quality Within Commercial Aircraft*. Atlanta: ASHRAE.

ATSB (2003) *Occurrence 200205307: Accident And Incident Report*. Canberra: ATSB.

BAe Systems (2001a) *ISB. 21-150. Inspection Service Bulletin -BAe 146 Series/Avro 146-RJ Series Aircraft*. Prestwick: BAe Systems (operations).

BAe Systems (2001b) *Operational Notice: NO.OP 16 (Issue 1) Manufacturers Operations Manual - AVRO 146-RJ - Notice To Aircrew*. BAe Systems.

BALPA (2005) 'Contaminated Air Protection - Air Safety And Cabin Air Quality', in Winder, C. (ed.) *Proceedings of the BALPA Contaminated Air Protection Air Safety and Cabin Air Quality International Aero Industry Conference . Held at*

- Imperial College, London, 20-21 April 2005*. Sydney: UNSW;
- BASI (1997) *Occurrence brief 199702276*. Canberra: BASI.
- Best, R. and Michaelis, S. (2005) 'Aircraft Air Quality Malfunction Incidents: Design, Servicing, And Policy Measures To Decrease Frequency And Severity Of Toxic Events', in Hocking, M. (ed.) *Air Quality In Airplane Cabins And Similar Enclosed Spaces*. Berlin: Springer (The Handbook Of Environmental Chemistry), pp. 249–266.
- BFU (2011) *Bulletin. Unfälle Und Störungen Beim Betrieb Ziviler Luftfahrzeuge*. November, Braunschweig: Bundesstelle für Flugunfalluntersuchung.
- BFU (2014) *BFU 803.1-14. Study Of Reported Occurrences In Conjunction With Cabin Air Quality In Transport Aircraft*. Braunschweig: Bundesstelle für Flugunfalluntersuchung.
- Bill, R. (1991) 'NASA/CP-10070. Army Research Concerns In Engine Sealing', in *Seals Flow Code Development, 26 March, 1991*. Cleveland: NASA.
- Boeing (2007) *Boeing MSDS No. 138541. Material Safety Data Sheet- MIL-PRF-23699*. Rev 08/09/2007. Seattle: Boeing.
- de Boer, J., Antelo, A. and van der Veen, I. et al. (2015) 'Tricresyl phosphate And The Aerotoxic Syndrome Of Flight Crew Members - Current Gaps In knowledge', *Chemosphere*, 119, pp. S58–S61.
- Boyce, M. (2012) *Gas Turbine Engineering Handbook (4th Edition)*. Elsevier. Available at: <https://app.knovel.com/web/toc.v/cid:kpGTEHE017>.
- Buist, L. (1989) *Memorandum - Air Conditioning After Engine Start*. Dan-Air (Unpublished report).
- CAA (2001) *AD 002-03-2001. Airworthiness Directive*. Gatwick: CAA.
- CAA (2004) *CAA PAPER 2004/04. Cabin Air Quality*. Gatwick: CAA.
- CAA (2011) *Mandatory Occurrence Reports: Engine Oil Fume Events: January 2006 - March 2011*. Gatwick: CAA (Unpublished report).

- Carvalho, R., Arukwe, A. and Ait-Aissa, S. et al. (2014) 'Mixtures Of Chemical Pollutants At European Legislation Safety Concentrations: How Safe Are They?', *Toxicological Sciences*, 141(1), pp. 218–233.
- Chaturvedi, A. (2009) *DOT/FAA/AM-09/8. Aerospace Toxicology: An Overview*. Oklahoma City: FAA, CAMI.
- Childs, D. (2005) 'Recent Advances In The Rotordynamic Behavior Of Annular Gas Seals', in *Advanced Topics And Technical Solutions In Dynamic Sealing EDF/LMS Workshop - Poitiers, October 2005*. Poitiers.
- Childs, P. (2013) *Mechanical Design Engineering Handbook*. Elsevier.
- Chupp, R., Hendricks, R. and Lattime, S. et al. (2006) *NASA/TM-2006-214341. Sealing In Turbomachinery*, NASA. Cleveland. Available at: <http://ntrs.nasa.gov/archive/nasa/casi.ntrs.nasa.gov/20060051674.pdf>.
- Chupp, R., Hendricks, R. and Steinetz, B. (2010) 'Gas Turbine Engines: Seals', *Encyclopedia Of Aerospace Engineering*. Wiley, pp. 987-1000.
- Company A (no date) *Maintenance Training Manual -Pneumatic Systems*. Unpublished Confidential Internal Document.
- Cone, J. (1983) *Interim Report No. 1- Association of Professional Flight Attendants*. San Francisco: San Francisco General Hospital Medical Centre (Unpublished report).
- COT (2007) *COT Statement 2007/06. Statement On The Review Of The Cabin Air Environment, Ill-health In Aircraft Crews And The Possible Relationship To Smoke/Fume Events In Aircraft*. London: Committee Of Toxicity.
- COT (2013) *Position Paper On Cabin Air*. London: Committee Of Toxicity. Available at: <http://cot.food.gov.uk/sites/default/files/cot/cotpospapcabin.pdf>.
- Crampton, A., Gleason, W. and Lifson, W. et al. (1952) *SAE 520198 - Performance of Turbo Engine Synthetic Oils*. Warrendale: SAE.
- Crump, D., Harrison, P. and Walton, C. (2011) *Aircraft Cabin Air Sampling Study; Part 1 and 2 of The Final Report*. Cranfield: Institute of Environment and

Health, Cranfield University.

DAC (1966) *Suitability Of Engine High Pressure Bleed Air For Environmental Control Usage - Assurance Tests*. Douglas Aircraft Corporation (Unpublished report).

Davidson, T., Cooley, T. and Way, J. (1955) *SAE 550080 - Air Force Experience With Synthetic Gas Turbine Lubricants*. Warrendale: SAE.

Davidson, G. (2014) 'Routine Mechanical Causes Of Aircraft Air Supply Contamination', *Journal of Biological Physics and Chemistry*, 14(4), pp. 90–93.

Day, G. (2015) *DOT/FAA/AM-15/20. Aircraft Cabin Bleed Air Contaminants: A Review*. Oklahoma City: FAA, CAMI.

Dechow, M. and Nurcombe, C. (2005) 'Aircraft Environmental Control Systems', in Hocking, M. (ed.) *Air Quality in Airplane Cabins and Similar Enclosed Spaces*. Berlin: Springer (The Handbook of Environmental Chemistry), pp. 3–24.

Dino, D. (1978) 'Self Active Pad Seal Application For High Pressure Engines', in *AGARD Conference Proceedings No. 237- Seal Technology In Gas Turbine Engines*. London: NATO-AGARD.

EASA (2009) *A-NPA-2009-10. Cabin Air Quality Onboard Large Aeroplanes*. Cologne: EASA.

EASA (2011) *Comment Response Document (CRD) To Advance Notice Of Proposed Amendment (A-NPA) 2009-10 - Cabin Air Quality Onboard Large Aeroplanes*. Cologne: EASA. Available at:
[https://www.easa.europa.eu/system/files/dfu/CRD to A-NPA 2009-10.pdf](https://www.easa.europa.eu/system/files/dfu/CRD%20to%20A-NPA%202009-10.pdf).

EASA (2015) *Certification Specifications And Acceptable Means Of Compliance For Engines. Amendment 4. CS-E 510 Safety Analysis*. Cologne: EASA.

ECA (2015) *ECA Position On Cabin Air Contamination*. Brussels, European Cockpit Association. Available at:
https://www.eurocockpit.be/sites/default/files/eca_position_paper_cabin_air_qu

ality_updated_15_1118_final.pdf.

Eckels, S., Jones, B. and Mann, G. et al (2014) 'Aircraft Recirculation Filter for Air-Quality and Incident Assessment', *Journal of Aircraft*, 51(1), pp. 320–326.

Edge, R. and Squires, A. (1969) *SAE 690424. Lubricant Evaluation And Systems design For Aircraft Gas Turbine Engines*. Warrendale: SAE.

Ensor, E. (1960) *Technical Paper No 723. - The Acute inhalation Toxicity Of The Pyrolysis Of Several Synthetic Lubricants*. Porton Down: Chemical Defence Experimental Establishment.

EPAAQ (2012) *Expert Panel On Aircraft Air Quality. Contamination Of Aircraft Cabin Air By Bleed Air – A Review Of The Evidence*. Canberra: CASA.

ESDU (2002) 'ESDU 80012. Dynamic Sealing Of Fluids . 1 : Guide To Selection Of Rotary Seals'. ESDU. Available at: <https://www.esdu.com>.

ESDU (2009) '09004. Labyrinth Seal Flow'. ESDU. Available at: <https://www.esdu.com>.

European Commission (2009) *Regulation (Ec) No 1272/2008 Of The European Parliament And Of The Council Of 16 December 2008 On Classification, Labelling And Packaging Of Substances And Mixtures (CLP)*. Available at: <http://echa.europa.eu/web/guest/information-on-chemicals/cl-inventory-database>.

ExxonMobil (2014) *Jet Engine Oil Consumption, ExxonMobil Aviation Tech Topics*. Available at: http://lubes.exxonmobil.com/aviation/learningandresources_tech-topics.aspx (Accessed: 1 June 2016).

ExxonMobil (2016a) *Jet Engine Oil System -Part One And Two, ExxonMobil Aviation Tech Topics*. ExxonMobil. Available at: http://lubes.exxonmobil.com/aviation/learningandresources_tech-topics.aspx (Accessed: 31 May 2016).

ExxonMobil (2016b) *Material Safety Data Sheet Material Safety Data Sheet:*

- Mobil Jet Oil II, ExxonMobil MSDS*. Available at:
<http://www.msds.exxonmobil.com/IntApps/psims/psims.aspx> (Accessed: 28 May 2016).
- FAA (2002) *Memo From FAA Associate Administrator For Regulation And Certification, AVR-1, to FAA Administrator : Proposed Implementation Of Cabin Air Quality Recommendations - Recommendation 1*. Washington: FAA.
- FAA (2004) *AD 2004-12-05: Airworthiness Directive*. Washington DC: FAA.
- FAA (2006) *FSAW 06 -05A. Guidance For Smoke/ Fumes In The Cockpit/ Cabin, Flight Standards Information Bulletin For Airworthiness*. Washington: FAA.
- FAA (2007) *CFR14 33 §33.75, Amendment 33-24. §33.75 - Safety Analysis*. Washington: FAA.
- FAA (2012a) *FAA-H-8083-32. The Aviation Maintenance Handbook– Powerplant*. vol. 2, Oklahoma City: FAA.
- FAA (2012b) *FAA-H-8083-32. The Aviation Maintenance Handbook– Powerplant*. vol. 1, Oklahoma City: FAA.
- Flitney, R. (2007) *Seals And Sealing Handbook*. 5th edn. Burlington: Butterworth-Heinemann.
- Flitney, R. (2014) 'A Description Of The Types Of High Speed Rotary Shaft Seals In Gas Turbine Engines And The Implications For Cabin Air Quality', *Journal of Biological Physics and Chemistry*, 14(4), pp. 85–89.
- Forames, P. (2011) *Case No: CV-11-900803. P Forames et al. V ST Aerospace Mobile, INC*. Circuit Court Of Mobile County, Alabama. Available at:
<http://ftpcontent4.worldnow.com/wbtv/complaintcrew2.pdf>.
- Fox, R. (2012) *Assessing Aircraft Supply Air To Recommend Compounds For Timely Warning Of Contamination*. (PhD Thesis) Northcentral University, Arizona. Available at: <http://library.ncu.edu/diss/GetAbstract/2126>.
- Gaume, J. (1973) *Analytical Considerations Concerned With Cephalagia On*

The DC-10. Long Beach: McDonnell Douglas Corporation (Unpublished report).

GCAQE (2016) *Global Cabin Air Quality Executive - Media*. Available at: <http://gcaqe.org/media/> (Accessed: 25 May 2016).

Guerzoni, F. (1999) *Presentation to SAE E34 Propulsion Lubricants Conference Cardiff, 1999. The Debate Over Aircraft Cabin Air Quality And Health: Implications For Aviation Turbine Lubricants*. Shell Global Solutions (Unpublished report).

Gunston, B. (2006) *The Development Of The Jet And Turbine Aero Engines*. 4th edn. Yeovil: Haynes.

Gutkowski, G., Page, R. and Peterson, M. (1953) *D-14766-2. B-52 Decontamination Program*. Seattle: Boeing (Unpublished report).

Harper, A. (2005) 'A Survey Of Health Effects In Aircrew Exposed To Airborne Contaminants', *J Occupational Health Safety - Aust NZ*, 21(5), pp. 433–439.

Harrison, R., Murawski, J. and Mcneely, E. et al. (2009) *Exposure To Aircraft Bleed Air Contaminants Among Airline Workers - A Guide For Health Care providers*. San Francisco: OHRCA.

Harrison, W. (2009) *Letter From ASHRAE President To FAA Administrator And EASA Executive Director, March 6, 2009*. ASHRAE. Available at: <http://ashsd.afacwa.org/docs/ashlet.pdf>.

Hauger, H., Cleeves, V. and Perlee, J. (1968) 'DC-9 Environmental Control Design And First Year's Service Experiences', *J Aircraft*, 5(1), pp. 64–72.

Hausherr, V., van Thriel, C. and Krug, A. et al. (2014) 'Impairment Of Glutamate Signaling In Mouse Central Nervous System Neurons In Vitro By Tri-Ortho-Cresyl Phosphate At Noncytotoxic Concentrations', *Toxicol Sci*, 142(1), pp. 274–284.

Hendricks, R. (1993) 'Environmental And Customer-Driven Seal Requirements.', in *Seals Flow Code Development-93, NASA CP 10134*. Cleveland: NASA.

- Hendricks, R. (1995) 'Turbomachine Sealing', in *Seals Code Development workshop*. NASA CP/10181. Cleveland: NASA.
- Hinrichs, P. (2015) 'Das Gift Fliegt Mit', *Die Welt*, 8 February. Available at: <http://www.welt.de/print/wams/politik/article137223944/Das-Gift-fliegt-mit.html>.
- HOL (2007) *House Of Lords Science And Technology Committee. Air Travel And Health: An Update*. London: House of Lords,. Available at: <http://www.publications.parliament.uk/pa/ld200708/ldselect/ldsctech/7/7we01.htm>.
- Holley, J. (2009) 'Reducing Smoke And Burning Odor Events', *Boeing Aero Quarterly*, pp. 6–9.
- Houtzager, M., Havermans, J. and Bos, J. (2013) *TNO 2013 R11976- Investigation Of Presence And Concentration Of Tricresyl Phosphates In Cockpits Of KLM Boeing 737 Aircraft During Normal Operational Conditions*. The Hague: TNO.
- ICAO (2015) *Cir 344-AN/202. Guidelines on Education, Training And Reporting Practices related To Fume Events*. Montréal: ICAO.
- ICSC (2016) *ICSC. International Programme On Chemical Safety*. Geneva: WHO. Available at: <http://www.who.int/ipcs/publications/icsc/en/>.
- Idahospudsblog (2014) *Steam Turbine Outage, Internet blog*. Available at: <http://idahospudsblog.blogspot.co.uk/2014/11/steam-turbine-outage.html> (Accessed: 11 June 2016).
- IFALPA (2013) *Safety Bulletin 13SAB006. Cabin Air Quality*. Montreal: IFALPA.
- IGHRC (2009) *IGHRC. Chemical Mixtures : A Framework For Assessing Risks To Human Health*. Cranfield: IEH, Cranfield University.
- Johnson, B. (2010) 'Internal Air And Lubrication Systems', *Encyclopedia Of Aerospace Engineering*. Wiley, pp. 977-986.
- Johnson, R., Swickert, M. and Bisson, E. (1952) *NACA TN 2846. Effective Lubrication Range for Steel Surfaces Boundary Lubricated at High Sliding*

Velocities by Various Classes of Synthetic Fluids. Washington: NACA.

Juan, G. and Amsellem, C. (2012) 'A320 Family Air And Bleed Working Group Activities - From Engineering To Airline Culture', *Airbus FAST 45*, December, pp. 16–21.

Kitzes, G. (1956) 'Cabin Air Contamination Problems In Jet Aircraft.', *Aviation Medicine*, 27(1), pp. 53–58.

Linke-Diesinger, A. (2008) *Systems of Commercial Turbofan Engines: An Introduction to Systems Functions*. Hamburg: Springer.

Loomis, T. and Krop, S. (1955) *MLSR No. 61 - Cabin Air Contamination In RB-57A Aircraft*. Maryland: Army Chemical Center.

Ludwig, L. (1978a) 'Gas Path Sealing In Turbine Engines', in *AGARD Conference Proceedings No. 237- Seal Technology In Gas Turbine Engines*. London: NATO-AGARD.

Ludwig, L. (1978b) 'Self-Acting Shaft Seals', in *AGARD Conference Proceedings No. 237- Seal Technology In Gas Turbine Engines*. London: NATO-AGARD.

Mackerer, C. and Ladov, E. (2000) 'Mobil Submission (14a)'; in *Inquiry Into Air Safety - BAe 146 Cabin Air Quality Vol 3*. Canberra: Parliament Of The Commonwealth Of Australia.

Mayhew, E. (1995) 'Air Force Seal Activities', in *Seals Code Development workshop. NASA CP/10181*. Cleveland: NASA.

Merron, G. (2007) 'HC 127960. Aircraft: Air Conditioning'. London: House of Commons, Parliament. Available at:
<http://www.publications.parliament.uk/pa/cm200607/cmhansrd/cm070319/text/70319w0001.htm>.

Michaelis, S. (2010) *Health and Flight Safety Implications from Exposure to Contaminated Air in Aircraft*. (PhD Thesis) UNSW, Sydney. Available at:
<http://handle.unsw.edu.au/1959.4/50342>.

Michaelis, S. (2011) 'Contaminated Aircraft Cabin Air', *Journal of Biological*

Physics and Chemistry, 11(4), pp. 132–145.

Montgomery, M., Wier, G., Zieve, F. and et al. (1977) 'Human Intoxication Following Inhalation Exposure to Synthetic Jet Lubricating Oil', *Clinical Toxicology*, 11(4), pp. 423–426.

Murawski, J. (2011) 'AIAA 2011-5089. Case Study: Analysis Of Reported Contaminated Air Events At One Major US Airline in 2009-10', in *41st International Conference on Environmental Systems 17 - 21 July 2011, Portland*. AIAA, pp. 1–11.

Nagda, N., Rector, H. and Li, Z. et al. (2001) *ASHRAE 959-RP. Determine Aircraft Supply Air Contaminants in the Engine Bleed Air Supply System on Commercial Aircraft*. Atlanta: ASHRAE.

NASA (1995) 'NASA 10181. Seals Code Development Workshop', in *Seals Code Development workshop*. Cleveland: NASA Lewis Research Center.

Available at:

<http://ntrs.nasa.gov/archive/nasa/casi.ntrs.nasa.gov/19960020369.pdf>.

NASA (1999) 'NASA/CP-1999-208916/Vol 1. 1999 NASA Seal/Secondary Air System Workshop', in *1998 NASA Seal/Secondary Air System Workshop*. NASA.

Nau, B. (1964) 'Hydrodynamics Of Face Seal Films', in *2nd Int. Conf. on Fluid Sealing*. Cranfield: BHR Group.

NRC (2002) *The Airliner Cabin Environment And The Health Of Passengers And Crew*. Washington: National Research Council (U.S.).

NSWDDT (2009) *Turner v Eastwest Airlines Limited [2009] NSWDDT 10. Dust Diseases Tribunal of New South Wales*. Available at:

<http://www.austlii.edu.au/au/cases/nsw/NSWDDT/2009/10.html>.

Overfelt, R. and Jones, B. (2013) *RITE-ACER-CoE-2013-02. Proposed Test Plans For A Study Of Bleed Air Quality In Commercial Airliners*. Auburn: RITE/ACER.

Overfelt, R., Jones, B. and Loo, S. et al. (2012) *RITE-ACER-CoE-2012-05. Sensors And Prognostics To mitigate Bleed Air Contamination Events*. Auburn: ACER.

Palsulich, J. and Riedel, R. (1956) *SAE 560171. Dynamic Seals For Aircraft Gas Turbine Engines*. Warrendale: SAE.

PCA (1999) *Hansard, BAe Oral Evidence - Inquiry Into Air Safety - BAe 146 Cabin Air Quality, Senate Committee Hansard*. 2 November, Canberra: Parliament Of The Commonwealth Of Australia.

PCA (2000) *Air Safety And Cabin Air Quality In The BAe 146 Aircraft - Report By The Senate Rural And Regional Affairs And Transport References Committee*. Canberra: Parliament Of The Commonwealth Of Australia.

Peitsch, D. (2003) 'Developments In Modern Aero-Engines To Minimize The Impact Of Bleed Air', in *Air Quality In Passenger Aircraft. Royal Aeronautical Society, London, 16-17 October 2003*. London: Rolls-Royce Deutschland.

Povinelli, V. (1975) 'Current Seal Designs And Future Requirements For Turbine Engine Seals And Bearings', *J. Aircraft*, 12(4), pp. 266–273.

Proctor, M. (2006) 'Forming A Turbomachinery Seals Working Group: An Overview And Discussion', in *NASA2006 NASA Seal/Secondary Air System Workshop, November 14-15, 2006*. Cleveland: NASA.

Przytulski, J., Haaser, F. and Granitz, C. et al. (2013) 'Patent. EP 1 255 024 B1- Methods And Systems For Preventing Gas Turbine Engine Lube Oil Leakage.' US: General Electric.

Rayman, R. (2002) 'Cabin Air Quality: An Overview', *Aviation, Space And Environmental medicine.*, 73(3), pp. 211–215.

Reddall, H. (1955) *SAE 550185. Elimination Of Engine Bleed Air Contamination*. Warrendale: SAE.

de Ree, H., van den Berg, M. and Brand, T. et al. (2014) 'Health Risk Assessment Of Exposure To TriCresyl Phosphates (TCPs) In Aircraft: A

Commentary', *NeuroToxicology*, 45, pp. 209–215.

Roberts, M., Buck, A. and Crumpler, M. et al. (2013) 'AIAA. Preliminary Evaluation Of NDIR CO 2 Sensors For Bleed Air Monitoring', in *43rd International Conference on Environmental Systems, July 14-18, 2013, Vail, CO. AIAA*.

Robson, C. (2002) *Real World Research: A Resource For Social Scientists And Practitioner-Researchers*. 2nd edn. Oxford: Blackwell.

Rolls-Royce (2005) *The Jet Engine*. 5th edn. Rolls-Royce.

Rosenberger, W. (2014) 'Air Quality In Aircraft Cabins – In Flight Measurements Of Organophosphates And Other Hazardous Substances In Different types', in *AIRMON 2014 Session VII 17th June, Marseille, France*. Hannover: Hannover Medical School.

Rosenberger, W., Beckmann, B. and Wrbitzky, R. (2016) 'Airborne Aldehydes In Cabin-Air Of Commercial Aircraft: Measurement By HPLC With UV Absorbance Detection Of 2,4-Dinitrophenylhydrazones', *Journal of Chromatography B*, 1019, pp. 117–127.

Rosenberger, W., Netz-Piepenbrink, S. and Wrbitzky, R. (2013) 'Untersuchungen Zum Vorkommen Von Mono- Und Diortho-Trikresylphosphaten In Der Innenraumlufte Von Flugzeugen', *Gefahrstoffe - Reinhaltung der Luft*, 73(4), pp. 138–143.

SAE (1981) *AIR 1539. Environmental Control System Contamination*. Warrendale: SAE.

SAE (2005) *AIR 4766/2- Airborne Chemicals In Aircraft Cabins, Development*. Warrendale: SAE.

Shaughnessy, D. and Dobek, L. (2005) 'High Misalignment Carbon Seals For The Fan Gear System Technologies.', in *NASA/CP-2006-214383/Vol1. 2005 NASA Seal/Secondary Air Delivery Workshop*. Cleveland: NASA.

Shehadi, M., Jones, B. and Hosni, M. (2015a) 'Bleed Air Contamination

Financial Related Costs on Board Commercial Flights', *SAE Int. J. Aerosp.*, 8(2), pp. 310–315.

Shehadi, M., Jones, B. and Hosni, M. (2015b) 'Characterization Of The Frequency And Nature Of Bleed Air Contamination Events In Commercial Aircraft', *Indoor Air*, (26), pp. 478–488.

SHK (2001) *Report RL 2001 : 41e. Incident Onboard Aircraft SE-DRE. Sweden, 12 November 1999*. Stockholm: Statens haverikommission (SHK) Board of Accident Investigation.

Skewis, W. H. (2011) *Mechanical Seal Failure Modes*. Support Systems Technology Corp. Available at:
[http://www.fmeainfocentre.com/updates/may2011/Mechanical seal failure modes.pdf](http://www.fmeainfocentre.com/updates/may2011/Mechanical%20seal%20failure%20modes.pdf).

Smith, C. (1978) 'American Airlines Operational And Maintenance Experience With Aerodynamic Seals And Oil Seals In Turbofan Engines', in *AGARD Conference Proceedings No. 237- Seal Technology In Gas Turbine Engines*. London: NATO-AGARD.

Solbu, K., Daae, H. and Olsen, R. et al. (2011) 'Organophosphates In Aircraft Cabin And Cockpit Air-Method Development And Measurements Of Contaminants', *J Environ Monit*, 13(5), pp. 1393–1403.

Spengler, J., Vallarino, J. and Mcneely, E. et al. (2012) *RITE-ACER-CoE-2012-6. In-Flight / Onboard Monitoring : ACER 's Component for ASHRAE, 1262, Part 2*. Boston: RITE/ACER.

Spengler, J. and Wilson, D. (2003) 'Air quality In aircraft', *J. Process Mechanical Engineering*, 217(4), pp. 323–335.

Stocker, H. (1978) 'Determining And Improving Labyrinth Seal Performance In Current And Advanced High Performance Gas Turbines', in *AGARD Conference Proceedings No. 237- Seal Technology In Gas Turbine Engines*. London: NATO-AGARD.

- Suppelsa, M. (2016) 'WGN Investigates The Boeing Papers: How Safe Is The Air Up There? - FAA And Boeing Statements', *WGN-TV*. Available at: <http://wgntv.com/2016/04/28/wgn-investigates-the-boeing-papers-how-safe-is-the-air-up-there/> (Accessed: 29 April 2016).
- Thompson, R; Hagshenas, B. (2006) 'Patent: US 2006/0042270 A1. Auxilliary Power Unit With An Oil-free Compressor.' US: Hamilton Sundstrand. Available at: <http://www.google.com/patents/US20060042270>.
- Tran, H. and Haselbacher, P. (2004) 'High-Performance Lift Augmentation Dynamic Seals For Turbine Bearing Compartments', *Sealing Technology*, (1), pp. 5–10.
- Treon, J., Cappel, J., Cleveland, F. and et al. (1955) 'The Toxicity Of The Products Formed by The Thermal Decomposition Of Certain Organic Substances', *Industrial Hygiene Quarterly*, (September), pp. 187–195.
- Ullah, R. (1995) 'Seals Research At Allied Signal', in *NASA 10181. Seals Code Development Workshop, June 14-15, 1995*. Cleveland: NASA.
- US Congress (2012) *Public Law 112 - 95 (2012). FAA Modernization and Reform Act of 2012 - H.R. 658 – Section 320, S. 917*. Washington: US Congress. Available at: <https://www.congress.gov/bill/112th-congress/house-bill/658>.
- Vera-barcelo, L. (2013) 'A Clean APU Means Clean Cabin Air', *Airbus, FAST 52*, August.
- Waddock, R. (1954) *Report No. SM 15195. Engine Compressor Bleed Air Contamination Study. XC-132 Project*,. Santa Monica: Douglas Aircraft Company (Unpublished report).
- Walker, P. (1990) *SAE-E31. Discussion Paper. Discussion On The Specification Limit For Total Organic Material In Cabin Bleed Air*. Rolls-Royce (Unpublished report).
- Wensheng, M., Hai, H. and Guoquan, F. et al. (2015) 'Labyrinth Seals Diameter

And Length Effect Study On Nonlinear Dynamics', *Procedia Engineering*, 99, pp. 1358–1364.

Whitlock, D. (1978) 'Oil Sealing Of Aero Engine Bearing Compartments', in *AGARD Coference Proceedings No. 237- Seal Technology In Gas Turbine Engines*. London: NATO- AGARD.

Wilcox, E. (2000) 'API Centrifugal Compressor Oil Seals And Support Systems — Types , Selection , And Field Troubleshooting', in *Proceedings Of The 29th Turbomachinery Symposium*.

Winder, C. and Michaelis, S. (2005) 'Aircraft Air Quality Malfunction Incidents: Causation, Regulatory, Reporting and Rates', in Hocking, M. (ed.) *Air Quality in Airplane Cabins and Similar Enclosed Spaces*. Berlin: Springer (The Handbook of Environmental Chemistry), pp. 211–228.

Zheng, X. and Berard, G. (2001) *AIAA 2001-3624 Development of Non-Contacting , Film-Riding Face Seals for Large-Diameter Gas Engines*. Reston: AIAA.

APPENDICES

Appendix A Selected Oil Fume Activities 1999-2016

Table A1 shows selected oil fumes research and actions undertaken between 1999 and 2016.

Table A:1 Selected Oil Fume Activities 1999-2016

Country	Year	Activity	Ref
Australia	1999/2000	Australian Senate Inquiry	1
Australia	2000	Conference	2
UK	2000	House of Lords Inquiry	3
US	2002	National Research Council	4
US	2003	Public Law Leading to \$15 million of ACER/RITE CAQ studies over 10 years	5
EU	2003-2009	Various EU/industry studies- CabinAir, ICE...	
UK	2005	International conference	6
UK	2007	House of Lords Inquiry	7
UK	2007	Committee of Toxicity	8

¹. PCA (2000) *Air Safety and Cabin Air Quality in the BAe 146 aircraft. Report by the Senate Rural and Regional Affairs and Transport References Committee*. Canberra: Parliament of

². UNSW (2001) 'Aviation Air Quality' in Winder, C. (ed.) *Proceedings of the Aviation Air Quality Symposium held at the University of New South Wales and the Australian Defense Force Academy, Canberra, 7 December 2000*. Sydney, UNSW

³. HOL (2000) *UK House of Lords Session 1999-2000 5th Report HL 121-I- Select Committee on Science and Technology - Air Travel and Health*. London: House of Lords

⁴. NRC (2002) *The Airliner Cabin Environment And The Health Of Passengers And Crew*. Washington: National Research Council

⁵. US Congress (2003) *Public Law 108 - 176. Air Quality In Aircraft Cabins S. 815. Vision 100-Century Of Aviation Reauthorization Act*. Washington: US Congress
Available at: <https://www.gpo.gov/fdsys/pkg/PLAW-108publ176/html/PLAW-108publ176.htm>

⁶. BALPA (2005) 'Contaminated Air Protection - Air Safety And Cabin Air Quality', in Winder, C. (ed.) *Proceedings of the BALPA Contaminated Air Protection Air Safety and Cabin Air Quality International Aero Industry Conference. Held at Imperial College, London, 20-21 April 2005*. Sydney: UNSW;

⁷. HOL (2007) *UK House of Lords Session 2007-2008 1st report HL 7- Select Committee On Science and Technology - Air Travel and Health - An Update*. London: House of Lords

France	2009	NYCO	9
US	2009	OHRCA	10
EU	2009	EASA-A-NPA	11
Australia	2010	Michaelis	12
UK	2011	Cranfield	13
EU	2012	EASA	14
US	2012	Public Law 112-95 Studies on CAQ, monitoring & cleaning air.	15
US	2012	Fox	16
EU	2012	Clean Sky	17
US	2012	TAP biomarker research	18
Australia	2012	Expert Panel on Aircraft Air Quality	19

⁸. COT (2007) *COT Statement 2007/06. Statement On The Review Of The Cabin Air Environment, ill health In Aircraft Crews And The Possible Relationship To Smoke/Fume Events In Aircraft*. London: Committee Of Toxicity.

⁹. NYCO (2009) *Letter from E. Piveteau, NYCO to EASA: EASA A-NPA No 2009-10: Potential Toxicity of Jet Engine Oils. 24 November 2009*. Paris: NYCO

¹⁰. Harrison, R. et al. (2008) OHRCA. *Exposure To Aircraft Bleed Air Contaminants Among Airline Workers A Guide For Health Care Providers. Occupational Health Research Consortium in Aviation, August 2008*. San Francisco: OHRCA

¹¹. EASA (2009) *A-NPA-2009-10. Cabin Air Quality Onboard Large Aeroplanes*. Cologne: EASA.

¹². Michaelis, S. (2010) *Health and Flight Safety Implications from Exposure to Contaminated Air in Aircraft*. (PhD Thesis) UNSW, Sydney. Available at: <http://handle.unsw.edu.au/1959.4/50342>.

¹³. Crump, D. et al. (2011) *Aircraft Cabin Air Sampling Study; Part 1 and 2 of The Final Report*. Cranfield: Institute of Environment and Health, Cranfield University.

¹⁴. EASA (2012) Decision No 2012/001/R of the Executive Director Of The European Aviation Safety Agency of 27th January 2012. Cologne: EASA

¹⁵. US Congress (2012) *Public Law 112 - 95 (2012). FAA Modernization and Reform Act of 2012 - H.R. 658 – Section 320, S. 917*. Washington: US Congress. Available at: <https://www.congress.gov/bill/112th-congress/house-bill/658>.

¹⁶. Fox, R. (2012) *Assessing Aircraft Supply Air to Recommend Compounds for Timely Warning of Contamination*. (PhD Thesis) Northcentral University, Arizona. Available at: <http://library.ncu.edu/diss/GetAbstract/2126>.

¹⁷. Clean Sky (2012) *Clean Sky, More Electrical Aircraft – Focus on Environmental Control and Ice protection*. Available at: http://www.cleansky.eu/sites/default/files/attached_documents/sgo-mea-20120210.pdf

¹⁸. Baker, P., Cole T. et al. (2012) Identifying Safer Antiwear Triarylphosphate Additives For Jet Engine Lubricants. *Chem Biol Interact* , 203: 257–264, 2013.

¹⁹. *EPAAQ (2012) Expert Panel On Aircraft Air Quality. Contamination Of Aircraft Cabin Air By Bleed Air – A Review Of The Evidence*. Canberra: CASA.

UK	2013	Committee of Toxicity	20
EU	2013	EN 4618 & prEN 4666: 2013 - withdrawn	21
US	2013	Nervous system autoantibodies research	22
Germany	2013	Real-time total carbon content detection systems	23
US	2013	ASHRAE	24
EU	2014	CEN - CAQ	25
Germany	2014	BFU	26
Holland	2014	REACH TCP review and Aerotoxic Syndrome review	27
International	2014	ICAO	28
Germany	2014	Low level TCP toxicity	29
US	2014	NASA, USAF, FAA VIPR study	
Holland	2014	MRI research	30

²⁰. COT (2013) *Position Paper On Cabin Air*. London: Committee of Toxicity.

²¹. CEN (2013) *CEN European Committee for Standardization. BT N 9345. prEN 4618:2013 and prEN 4666:2013 (airplane air quality) – Enquiry results Decision BT 31/2013, September, 2013*. Brussels: CEN

²². Abou-Donia, M. B., Abou-Donia, M. M. et al. (2013) 'Autoantibodies To Nervous System-Specific Proteins Are Elevated In Sera Of Flight Crew Members: Biomarkers For Nervous System Injury', *J Toxicol Environ Health A*, 76(6), pp. 363–380.

²³. Gröger & Obst (2013) *GO ATC Technical Information*. Wolfratshausen: Gröger & Obst Vertriebs- und Service GmbH

²⁴. ASHRAE (2013) *Standard 161-2013. Air Quality Within Commercial Aircraft*. Atlanta: ASHRAE.

²⁵. CEN (2015) *CEN European Committee for Standardization. CEN/TC 436. Project Committee - Cabin Air Quality on Civil Aircraft - Chemical Agents*. Brussels: CEN

²⁶. BFU (2014) *BFU 803.1-14. Study Of Reported Occurrences In Conjunction With Cabin Air Quality In Transport Aircraft. Braunschweig: Bundesstelle für Flugunfalluntersuchung*.

²⁷. RIVM (2015). 'Aerotoxic Syndrome RIVM Approach' *Presentation given at GCAQE annual meeting, London, February 25, 2015*. Bilthoven: National Institute for Public Health and Environment

²⁸. ICAO (2015) *Cir 344-AN/202. Guidelines on Education, Training And Reporting Practices related To Fume Events*. Montréal: ICAO

²⁹. Hausherr, V., van Thriel, C., Krug, A. et al. (2014) 'Impairment Of Glutamate Signaling In Mouse Central Nervous System Neurons In Vitro By Tri-Ortho-Cresyl Phosphate At Noncytotoxic Concentrations', *Toxicol Sci*, 142(1), pp. 274–284.

³⁰. Reneman, L. et al. (2015) 'Cognitive Impairment and Associated Loss in Brain White Microstructure in Aircrew Members Exposed to Engine Oil Fumes', *Brain Imaging and Behavior*, 1-8

UK	2014	Innovate	31
UK	2014	PALL	32
EU	2014	EASA	33
EU	2015	EASA	34
EU	2015	Future Sky	35
Holland	2015	TCP research	36
International	2015	IATA	37
US	Various	SAE AIR 4766/1; AIR 4766/2; ARP 4418A; AIR 1168-7; ARP 1796; ARP85E; AIR1116	

³¹. Research Councils UK /Innovate UK (2014) *Advanced Online Biosensor for Aircraft Cabin Safety*. Available at: <http://gtr.rcuk.ac.uk/projects?ref=101783>

³². Pall (2014) 'PC 100 PUREair - Filter Technology for the 757 Aircraft.' *Presentation given at GCAQE annual meeting, London, February 25, 2015*. Portsmouth: PAL Corporation

³³. EASA (2014) *Tender: EASA.2014.OP.16 (CAQ) Preliminary Cabin Air Quality Measurement Campaign*. Cologne: EASA

³⁴. EASA (2015) *Tender: EASA.2015.HVP.23. Characterisation of the Toxicity of Aviation Turbine Engine Oils After Pyrolysis (AVOIL)*. Cologne: EASA

³⁵. Future Sky (2015) *Safety -Theme 4: Project 7. Mitigating The Risk of Fire, Smoke & Fumes*. European Research Establishment in Aeronautics. Available at: <http://www.futuresky.eu/projects/safety>

³⁶. Mansveld, W. (2013) *Letter from the Secretary of State of Infrastructure and Environment, The Netherlands*. Available at: <https://zoek.officielebekendmakingen.nl/kst-31936-232.odt>

³⁷. IATA (2015) International Air Transport Association. *IATA Guidance For Airline Health and Safety Staff on the Medical Response to Cabin Air Quality Events*. Geneva: IATA

Appendix B EASA and FAA Certification Requirements and Guidance Material - Airframe & Engine/APU

Table B1 lists the airframe (25.1309) failure conditions and engine/APU safety analysis effects for EASA and FAA (§33.75; CS-E 510; CS-APU 210) regulation and standards as well as guidance material relevant to clean air requirements.

Table B:1 EASA and FAA Certification Requirements and AMC - Airframe & Engine

AIRFRAME LEVEL

FAA	EASA
Regulation/standard	
<p>CFR 14 25.1309 - Airworthiness standards - equipment</p> <p>Failure condition:</p> <ol style="list-style-type: none"> Reducing ability of crew to cope with adverse operating conditions. <ul style="list-style-type: none"> Improbable Preventing safe flight & landing <ul style="list-style-type: none"> Extremely improbable 	<p>CS 25.1309 - Equipment, systems and installation design requirements</p> <p>Failure condition:</p> <ol style="list-style-type: none"> Major <ul style="list-style-type: none"> Remote Hazardous <ul style="list-style-type: none"> Extremely remote Catastrophic <ul style="list-style-type: none"> Extremely improbable
Guidance Material (Advisory Circular - CS AMC)	
<p>AC 25.1309-1A – Failure conditions</p> <p>1. Minor - Crew actions well within capabilities - slight increase in workload - some inconvenience to occupants.</p> <ul style="list-style-type: none"> Probable 1×10^{-5} /fh <p>2. Major - Reduce ability of crew to cope with adverse operating conditions such that there would be: Significant increase in crew workload or in conditions impairing crew efficiency or some discomfort to occupants;</p>	<p>AMC 25.1309 – Failure conditions</p> <p>1. Minor - Crew actions well within capabilities - slight increase in workload - some physical discomfort to cabin crew or passengers.</p> <ul style="list-style-type: none"> Probable $> 1 \times 10^{-5}$ /fh Figure 2 <p>2. Major - Reduce ability of crew to cope with adverse operating conditions such that there would be: Significant increase in crew workload or in conditions impairing crew efficiency or discomfort to flight crew or physical distress to cabin crew or passengers, possibly</p>

<p>Higher workload or physical distress such that crew can't be relied upon to perform tasks accurately or completely</p> <ul style="list-style-type: none"> • Improbable • $\leq 1 \times 10^{-5} - > 1 \times 10^{-9} / \text{fh}$ <p>3. Catastrophic - Prevention of continued safe flight & landing.</p> <ul style="list-style-type: none"> • Extremely improbable • $\leq 1 \times 10^{-9} / \text{fh}$ 	<p>including injuries</p> <ul style="list-style-type: none"> • Remote • $\leq 1 \times 10^{-5} - > 1 \times 10^{-7} / \text{fh}$. <p>3. Hazardous - excessive workload or physical distress such that flight crew can't be relied upon to perform tasks accurately or completely - serious or fatal injury to a small number of occupants other than flight crew</p> <ul style="list-style-type: none"> • Extremely remote • 1×10^{-7} or less - $> 1 \times 10^{-9} / \text{fh}$ <p>4. Catastrophic - Multiple fatalities, usually with loss of aeroplane (previously prevent continued safe flight & landing)</p> <ul style="list-style-type: none"> • Extremely improbable • $\leq 1 \times 10^{-9} / \text{fh}$
<p>Anticipation of failure conditions</p> <p>Probable: One or more times during entire operational life of each aeroplane;</p> <p>Improbable (FAA): Will not occur during entire operational life of a single random aeroplane - may occur occasionally during life of all aeroplanes of type;</p> <p>Remote (EASA): Unlikely to occur to each aeroplane during its total life, but may occur several times during life of a number of aircraft of type;</p> <p>Extremely remote (EASA): Will not occur to each aeroplane during its life but may occur a few times during total life of all aeroplanes of type;</p> <p>Extremely improbable: Will not occur during life of all aeroplanes of type.</p> <p>Compliance shown by analysis and where necessary, appropriate ground, flight or simulator tests.</p>	

ENGINE - APU LEVEL

FAA	EASA
Regulation/standard	
<p>CFR 14 33.75 - Safety analysis - Engines</p> <p>1. Hazardous engine effects -</p> <ul style="list-style-type: none"> • Extremely remote • 10^{-7} to $10^{-9} / \text{efh}$ <p>In practice - $< 10^{-8} / \text{efh}$</p>	<p>CS-E 510 & CS-APU 210 - Safety analysis - Engines & APU</p> <p>Hazardous engine/APU effects</p> <ul style="list-style-type: none"> • Extremely remote • $< 10^{-7} / \text{efh}$ or APU operating hour (APU o/h) <p>In practice - $< 10^{-8} / \text{efh}$ or APU o/h</p>

<p>Concentration of toxic products in engine bleed air intended for the cabin sufficient to incapacitate crew or passengers</p> <p>2. Major engine effects</p> <ul style="list-style-type: none"> • Remote • 10^{-5} to 10^{-7}/efh <p>Safety analysis: must include compressor bleed systems</p>	<p>Concentration of toxic products in engine/APU bleed air intended for the cabin sufficient to incapacitate crew or passengers</p> <p>2. Major engine effects</p> <ul style="list-style-type: none"> • Remote • $<10^{-5}$/efh or APU o/h <p>Safety analysis: must include compressor bleed systems</p>
<p align="center">Guidance Material (FAA Advisory Circular - CS AMC)</p>	
<p>AC 33.75-1A</p> <p>1. Hazardous Engine effects</p> <p>Toxic products:</p> <ul style="list-style-type: none"> • Generation and delivery of toxic products caused by abnormal engine operation sufficient to incapacitate crew or passengers during flight. <p>e.g. rapid flow of toxic products impossible to stop prior to incapacitation; no effective means to prevent flow of toxic products to crew/passenger areas; toxic products impossible to detect prior to incapacitation.</p> <ul style="list-style-type: none"> • Degradation of oil leaking into compressor airflow. <p>No assumptions including cabin air mixing/dilution.</p> <p>Intent is to address relative concentration of toxic products in bleed air delivery.</p> <p>Significant concentrations of toxic products - sufficient to incapacitate persons exposed</p> <p>Concentration & delivery rates should be included in engine/APU installation guide</p> <p>Major engine effects</p> <ul style="list-style-type: none"> • Concentration of toxic products in engine/APU bleed air for the cabin 	<p>AMC E 510 - AMC CS-APU 210</p> <p>1. Hazardous Engine/APU effects</p> <p>Toxic products:</p> <ul style="list-style-type: none"> • Generation and delivery of toxic products caused by abnormal engine operation sufficient to incapacitate crew or passengers during flight. <p>e.g. rapid flow of toxic products impossible to stop prior to incapacitation; no effective means to prevent flow of toxic products to crew/passenger areas; toxic products impossible to detect prior to incapacitation</p> <ul style="list-style-type: none"> • Degradation of oil leaking into compressor airflow <p>No assumptions including cabin air mixing/dilution</p> <p>Intent is to address relative concentration of toxic products in bleed air delivery</p> <p>Significant concentrations of toxic products - sufficient to incapacitate persons exposed</p> <p>Concentration & delivery rates should be included in engine/APU installation guide</p> <p>Major engine/APU effects</p> <ul style="list-style-type: none"> • Concentration of toxic products in engine/APU bleed air for the cabin sufficient to degrade crew performance <p>Toxic products in bleed air are slow-enough acting and/or are readily detectable so as to</p>

<p>sufficient to degrade crew performance</p> <p>Toxic products in bleed air are slow-enough acting and/or are readily detectable so as to be stopped prior to incapacitation.</p> <p>Possible reductions in crew capabilities due to exposure while identifying & stopping products to be considered</p> <p>APU – see FAA TSO-C77b</p> <p>Other: Proof: In dealing with such low probabilities, absolute proof is not possible with reliance placed on good engineering judgement, previous experience, sound design & test philosophies</p> <p>Toxic products: products that has effect of a poison when humans are exposed to them</p>	<p>be stopped prior to incapacitation.</p> <p>Possible reductions in crew capabilities due to exposure while identifying & stopping products to be considered</p> <p>Other: Proof: In dealing with such low probabilities, absolute proof is not possible with reliance placed on good engineering judgement, previous experience, sound design & test philosophies</p> <p>Toxic products: products that has effect of a poison when humans are exposed to them</p>
--	--

Appendix C Engine Oil System

Figure C1 and C2 below show typical oil systems. Figure C3 shows simplified oil system schematic sections.

Figure C1: Engine Oil System - Trent 500

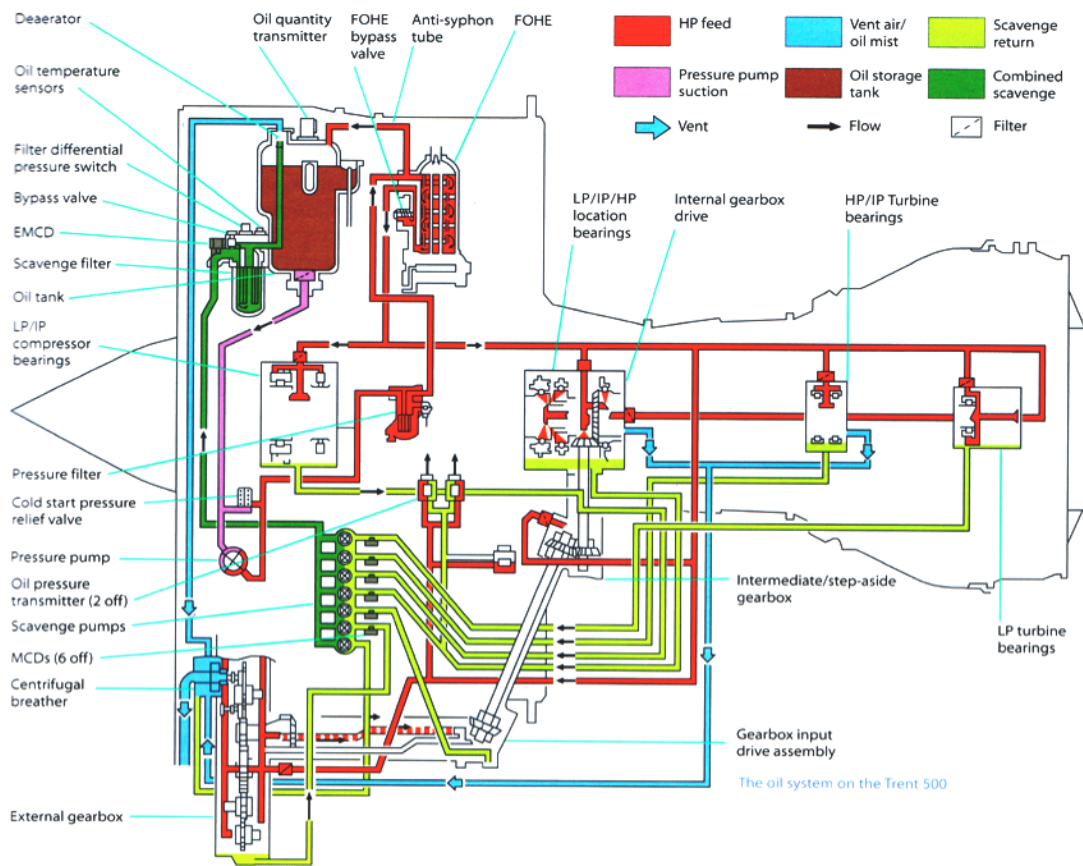

Source: (Rolls-Royce, 2005)

Figure C2: Jet Engine Oil Systems

Typical Jet Engine Oil System

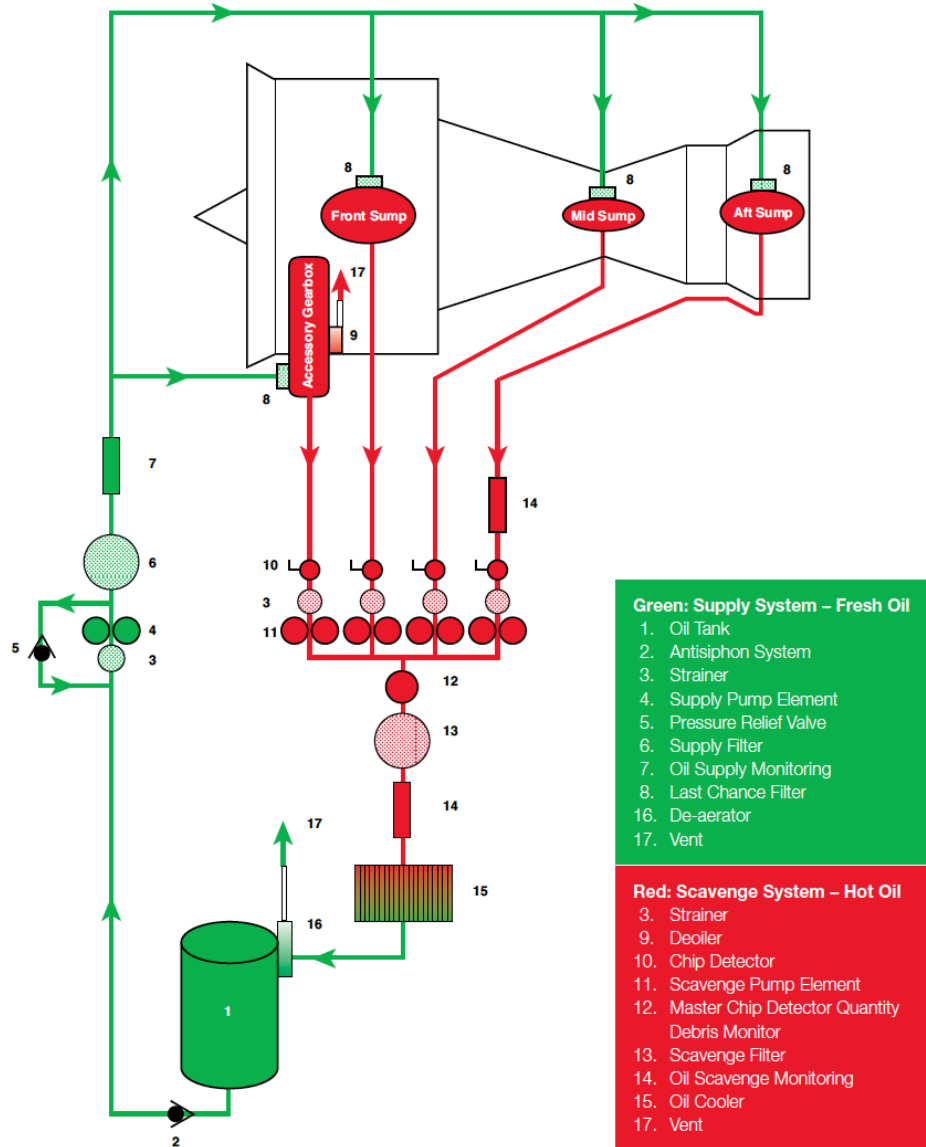

Source: Jet Engine Oil System - (ExxonMobil, 2016a)

Figure C3: Simplified Oil System Schematic Sections

A. Simplified Oil Supply System

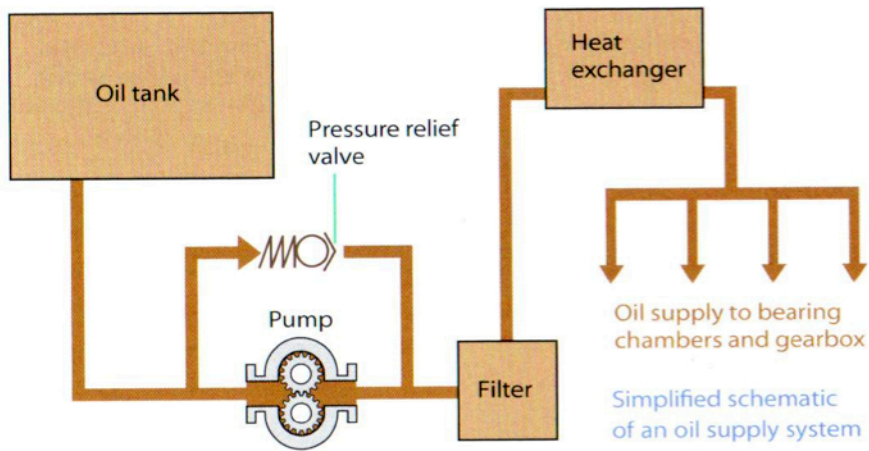

B. Simplified oil scavenge System

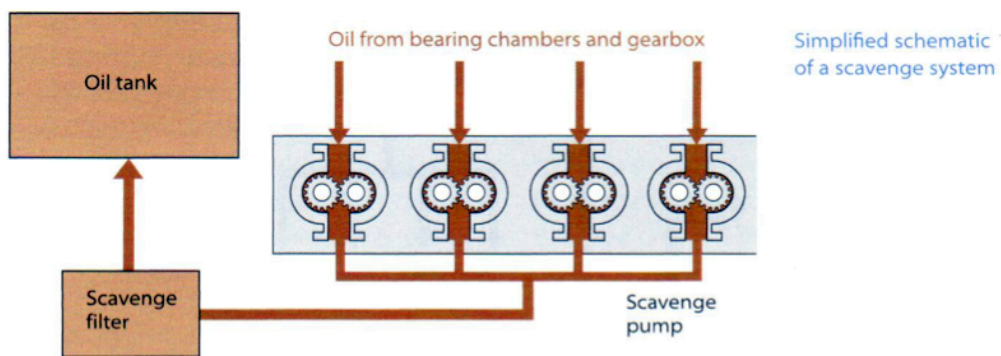

C. Simplified oil vent system

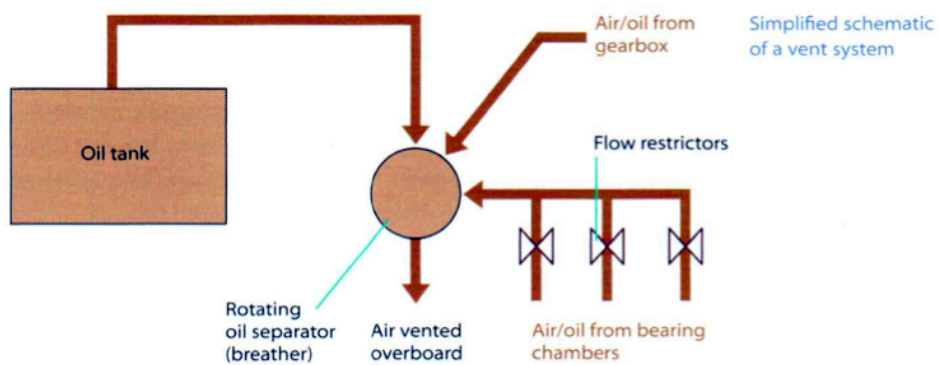

Source: (Rolls-Royce, 2005)

Appendix D Seal Technology Comparison

Table D1 provides a comparison of varying seal technologies.

Table D:1 Seal Technology Comparison

	Knife edge	Brush seal	Radial contact seal	Radial lift seal	Axial contact seal	Axial lift seal
Axial displacement	No change on seal performance	No change on seal performance	No change on seal performance	No change on seal performance	Axial spring design to support axial displacement	Axial spring and air film to support axial displacement
Radial displacement	Risk of interference	Wear increase on fibers	Risk of interference	Air film reduces risk of interference	Design will reduce coning effect	Air film makes no change on seal performance
Rubbing wear	Radial clearance is high enough to avoid wear	No radial clearance, seal wear by friction	No radial clearance, seal wear by friction	Air film reduce friction and wear	Friction and wear, cooling reduce wear, cocking risk	Air film avoid friction and wear
Air leakage	Big radial clearance will give big air leakage	Big air leakage through seal fibers gap	Low radial clearance, moderate air leakage	Low radial clearance moderate air leakage	Very small seal gap will give very low air leakage	Very small seal gap will give very low air leakage
Life and MTBO	No wear, seal life and MTBO are very long	Fibers wear giving very short seal life and MTBO	Carbon wear gives moderate seal life and MTBO	Low wear gives long seal life and MTBO	Carbon wear gives moderate seal life and MTBO	No wear gives very long seal life and MTBO
Oil runner cooling	No friction, no oil cooling for runner	Friction, oil cooling is necessary for runner	Friction, oil cooling is necessary for runner	Friction, oil cooling is necessary for runner	Friction, oil cooling is necessary for runner	No friction, no oil cooling for runner
Engine performance	High air loss, low engine performance, high SFC	Air loss, oil cooling, low performance, high SFC	Air loss, oil cooling, low performance, high SFC	Moderate air loss reduce performance, moderate SFC	Moderate air loss reduce performance, moderate SFC	Low air loss high engine performance, low SFC
Seal system weight (incl. cooling system weight)	High	High	High	Moderate	High	Low seal system (no cooling) weight
Engine operating cost	High	High	High	Moderate	High	Low
Oil consumption	High air leakage gives high oil consumption	High air leakage gives high oil consumption	High air leakage gives high oil consumption	Moderate air leakage gives moderate oil consumption	Low air leakage gives low oil consumption	Low air leakage gives low oil consumption
Reverse pressure gives oil pollution	High oil loss, oil pollution in cabin	High oil loss, oil pollution in cabin	High oil loss, oil pollution in cabin	High oil loss, oil pollution in cabin	High oil loss, oil pollution in cabin	No oil loss in reverse pressure, no oil pollution

Source: (Tran and Haselbacher, 2004)

